

**Part No. 060310-10, Rev. C**  
**September 2012**

# **OmniSwitch 10K**

## **Hardware Users Guide**

Alcatel-Lucent 

[www.alcatel-lucent.com](http://www.alcatel-lucent.com)

---

This user guide documents OmniSwitch 10K hardware, including chassis and associated components. The specifications described in this guide are subject to change without notice.

Copyright © 2012 by Alcatel-Lucent. All rights reserved. This document may not be reproduced in whole or in part without the express written permission of Alcatel-Lucent.

OmniSwitch<sup>®</sup>, Alcatel-Lucent<sup>®</sup> and the Alcatel-Lucent logo are registered trademarks of Alcatel-Lucent.



**26801 West Agoura Road  
Calabasas, CA 91301  
(818) 880-3500 FAX (818) 880-3505  
U,S, Customer Support—(800) 995-2696  
International Customer Support—(818) 878-4507  
[www.alcatel-lucent.com](http://www.alcatel-lucent.com)  
[support@ind.alcatel.com](mailto:support@ind.alcatel.com)**

# Contents

	<b>About This Guide</b> .....	vii
	Supported Platforms .....	vii
	Who Should Read this Manual? .....	vii
	When Should I Read this Manual? .....	vii
	What is in this Manual? .....	viii
	What is Not in this Manual? .....	viii
	How is the Information Organized? .....	viii
	Documentation Roadmap .....	ix
	Related Documentation .....	xi
	Technical Support .....	xii
<b>Chapter 1</b>	<b>OmniSwitch 10K</b> .....	1-1
	OmniSwitch 10K Availability Features .....	1-1
	Hardware Redundancy .....	1-1
	Smart Continuous Switching .....	1-2
	Hot Swapping .....	1-2
	Hardware Monitoring .....	1-3
	Power Checking Sequence .....	1-3
<b>Chapter 2</b>	<b>Chassis and Power Supplies</b> .....	2-1
	OmniSwitch 10K Chassis .....	2-2
	Chassis Slot Numbering .....	2-3
	Mounting the Switch .....	2-4
	Lifting the Chassis .....	2-4
	General Mounting Recommendations .....	2-5
	Airflow Recommendations .....	2-6
	Blank Cover Panels .....	2-7
	Rack-Mounting .....	2-8
	Standalone (Non-Rack Mounted) Installations .....	2-9
	Power Supplies .....	2-10
	OS10K-AC-2500 .....	2-10
	OS10K-DC-2400 .....	2-11
	DC Power Supply Connection .....	2-12
	Connecting a DC Cable Harness to the Chassis Power Supply .....	2-12
	Connecting a DC Cable Harness to the DC Power Source .....	2-12
	Power Supply Redundancy .....	2-13
	120V Applications .....	2-13

240V Applications .....	2-13
DC Applications .....	2-13
Chassis Power Budget .....	2-14
Checking Chassis Power Before Adding Components .....	2-14
Installing Power Supplies .....	2-15
Removing a Power Supply .....	2-17
Chassis Fan Trays .....	2-19
Removing Fan Trays .....	2-20
Installing Fan Trays .....	2-21
Grounding the Chassis .....	2-22
Monitoring Chassis Components .....	2-23
Viewing Chassis Slot Information .....	2-23
Monitoring Chassis Temperature .....	2-24
Temperature Errors .....	2-25
Monitoring Fan Tray Status .....	2-26
Fan Tray Redundancy .....	2-26
<b>Chapter 3 Chassis Management and Fabric Modules .....</b>	<b>3-1</b>
Chassis Management Module (CMM) .....	3-1
Chassis Fabric Module (CFM) .....	3-1
CMM and CFM Slot Locations .....	3-1
OS10K-CMM Front Panel .....	3-2
OS10K-CFM Front Panel .....	3-3
CMM/CFM LED Status Indicators .....	3-4
Installing CMM and CFM Modules .....	3-5
Caution: Pinch Point Hazard .....	3-6
Console Port .....	3-8
Serial Connection to the Console Port .....	3-8
CMM Redundancy .....	3-9
CMM Failover Sequence .....	3-9
Synchronizing the Primary and Secondary CMMs .....	3-9
Hot Swapping CMM Modules .....	3-10
Hot Swap Requirements .....	3-10
Managing CMM Modules .....	3-11
Reloading a CMM Module .....	3-11
Monitoring CMM Modules .....	3-12
Front Panel LEDs .....	3-12
Accessing General CMM Information .....	3-12
CMM Hardware Information .....	3-12
Operating Status of CMM-Related Components .....	3-13
Chassis Switching Fabric .....	3-14
Fabric Boards and Chassis Bandwidth .....	3-14
Pinouts .....	3-15

<b>Chapter 4</b>	<b>Network Interface (NI) Modules</b> .....	4-1
	In This Chapter .....	4-1
	GNI Modules .....	4-2
	XNI Modules .....	4-2
	QNI Modules .....	4-2
	OS10K-GNI-C48E Front Panel .....	4-3
	OS10K-GNI-U48E Front Panel .....	4-4
	OS10K-XNI-U32S Front Panel .....	4-5
	OS10K-XNI-U32E Front Panel .....	4-6
	OS10K-XNI-U16E Front Panel .....	4-7
	OS10K-XNI-U16L Front Panel .....	4-8
	OS10K-QNI-U4E Front Panel .....	4-9
	OS10K-QNI-U8E Front Panel .....	4-10
	Monitoring NI Modules .....	4-11
	Front Panel LEDs .....	4-11
	Accessing General NI Information .....	4-11
	Removing and Adding NI Modules .....	4-12
	Removing a Module .....	4-13
	Adding a Module .....	4-14
	Pinouts .....	4-15
	10/100 Mbps Ethernet Port – RJ-45 Pinout .....	4-15
	Gigabit Ethernet Port – RJ-45 Pinout .....	4-15
	Handling Fiber and Fiber Optic Connectors .....	4-16
	Use Premium Grade Cables .....	4-16
	Keep Your Fiber Optic Connectors Clean .....	4-16
	Keep the Transceiver Interface Clean .....	4-17
	Attenuate Properly .....	4-17
<b>Appendix A</b>	<b>Regulatory Compliance and Safety Information</b> .....	A-1
	Declaration of Conformity: CE Mark .....	A-1
	Waste Electrical and Electronic Equipment (WEEE) Statement .....	A-1
	China RoHS: Hazardous Substance Table .....	A-2
	Standards Compliance .....	A-4
	FCC Class A, Part 15 .....	A-5
	Canada Class A Statement .....	A-5
	JATE .....	A-5
	CISPR22 Class A warning .....	A-6
	VCCI .....	A-6
	Class A Warning for Taiwan and Other Chinese Markets .....	A-6
	Translated Safety Warnings .....	A-7
	Chassis Lifting Warning .....	A-7
	Blank Panels Warning .....	A-7

---

Electrical Storm Warning .....	A-7
Installation Warning .....	A-8
Invisible Laser Radiation Warning .....	A-8
Operating Voltage Warning .....	A-8
Power Disconnection Warning .....	A-9
Proper Earthing Requirement Warning .....	A-9
DC Power Supply Connection Warning .....	A-10
Read Important Safety Information Warning .....	A-10
Restricted Access Location Warning .....	A-10
Wrist Strap Warning .....	A-11
Instrucciones de seguridad en español .....	A-12
Advertencia sobre el levantamiento del chasis .....	A-12
Advertencia de las tapaderas en blanco .....	A-12
Advertencia en caso de tormenta eléctrica .....	A-12
Advertencia de instalación .....	A-12
Advertencia de radiación láser invisible .....	A-12
Advertencia de la batería de litio .....	A-12
Advertencia sobre la tensión de operación .....	A-12
Advertencia sobre la desconexión de la fuente .....	A-12
Advertencia sobre una apropiada conexión a tierra .....	A-13
Leer “información importante de seguridad” .....	A-13
Advertencia de acceso restringido .....	A-13
Advertencia de pulsera antiestática .....	A-13
Clase de seguridad .....	A-13
Advertencia de fuentes de poder .....	A-13

# About This Guide

This *OmniSwitch 10K Hardware Users Guide* describes OmniSwitch 10K switch components and basic switch hardware procedures.

## Supported Platforms

The information in this guide applies only to OmniSwitch 10K switches.

## Who Should Read this Manual?

The audience for this users guide is network administrators and IT support personnel who need to configure, maintain, and monitor switches and routers in a live network. However, anyone wishing to gain knowledge of OmniSwitch 10K hardware will benefit from the material in this guide.

## When Should I Read this Manual?

Read this guide as soon as you are ready to familiarize yourself with your switch hardware components. You should have already stepped through the first login procedures and read the brief hardware overviews in the *OmniSwitch 10K Getting Started Guide*.

You should already be familiar with the very basics of the switch hardware, such as module LEDs and module installation procedures. This manual will help you understand your switch hardware components (chassis, cooling fans, power supplies, Network Interface modules, Chassis Management Modules, switching fabric, etc.) in greater depth.

---

## What is in this Manual?

This users guide includes the following hardware-related information:

- Descriptions of “Availability” features.
- Technical specifications for chassis, power supplies, Network Interface (NI) modules, and Chassis Management Modules (CMMs).
- Power supply requirements.
- The dynamics of chassis airflow, including detailed illustrations of proper and improper airflow configurations.
- Hot swapping power supplies, fan trays, Chassis Management Modules (CMMs), Chassis Fabric Modules (CFMs) and Network Interface (NI) modules.
- Installation and removal procedures for power supplies, fan trays, Network Interface (NI) modules, and Chassis Management Modules (CMMs).
- Detailed illustrations and LED descriptions for power supplies, Network Interface (NI) modules, and Chassis Management Modules (CMMs).
- CMM redundancy.
- Hardware-related Command Line Interface (CLI) commands.

## What is Not in this Manual?

The descriptive and procedural information in this manual focuses on switch hardware. It includes information on some CLI commands that pertain directly to hardware configuration, but it is not intended as a software users guide. There are several OmniSwitch users guides that focus on switch software configuration. Consult those guides for detailed information and examples for configuring your switch software to operate in a live network environment. See [“Documentation Roadmap” on page -ix](#) and [“Related Documentation” on page -xi](#) for further information on software configuration guides available for your switch.

## How is the Information Organized?

Each chapter in this guide focuses on a specific hardware component, such as the Chassis Management Module (CMM), or a set of hardware components. All descriptive, technical specification, and procedural information for a hardware component can be found in the chapter dedicated to that component.



---

# Documentation Roadmap

The OmniSwitch user documentation suite was designed to supply you with information at several critical junctures of the configuration process. The following section outlines a roadmap of the manuals that will help you at each stage of the configuration process. Under each stage, we point you to the manual or manuals that will be most helpful to you.

## Stage 1: Using the Switch for the First Time

**Pertinent Documentation:** *OmniSwitch 10K Getting Started Guide*  
*Release Notes*

A hard-copy *OmniSwitch 10K Getting Started Guide* is included with your switch; this guide provides all the information you need to get your switch up and running the first time. It provides information on unpacking the switch, rack mounting the switch, installing NI modules, unlocking access control, setting the switch's IP address, and setting up a password. It also includes succinct overview information on fundamental aspects of the switch, such as hardware LEDs, the software directory structure, CLI conventions, and web-based management.

At this time you should also familiarize yourself with the Release Notes that accompanied your switch. This document includes important information on feature limitations that are not included in other user guides.

## Stage 2: Gaining Familiarity with Basic Switch Functions

**Pertinent Documentation:** *OmniSwitch 10K Hardware Users Guide*  
*OmniSwitch AOS Release 7 Switch Management Guide*

Once you have your switch up and running, you will want to begin investigating basic aspects of its hardware and software. Information about switch hardware is provided in the *OmniSwitch 10K Hardware Guide*. This guide provides specifications, illustrations, and descriptions of all hardware components, such as chassis, power supplies, Chassis Management Modules (CMMs), Network Interface (NI) modules, and cooling fans. It also includes steps for common procedures, such as removing and installing switch components.

This guide is the primary users guide for the basic software features on a single switch. This guide contains information on the switch directory structure, basic file and directory utilities, switch access security, SNMP, and web-based management. It is recommended that you read this guide before connecting your switch to the network.

## Stage 3: Integrating the Switch Into a Network

**Pertinent Documentation:** *OmniSwitch AOS Release 7 Network Configuration Guide*  
*OmniSwitch AOS Release 7 Advanced Routing Configuration Guide*

When you are ready to connect your switch to the network, you will need to learn how the OmniSwitch implements fundamental software features, such as 802.1Q, VLANs, Spanning Tree, and network routing protocols. This guide contains overview information, procedures, and examples on how standard networking technologies are configured on the OmniSwitch.

The guide includes configuration information for networks using advanced routing technologies (OSPF and BGP) and multicast routing protocols (DVMRP and PIM-SM).

---

## **Anytime**

The *OmniSwitch CLI Reference Guide* contains comprehensive information on all CLI commands supported by the switch. This guide includes syntax, default, usage, example, related CLI command, and CLI-to-MIB variable mapping information for all CLI commands supported by the switch. This guide can be consulted anytime during the configuration process to find detailed and specific information on each CLI command.

---

## Related Documentation

The following are the titles and descriptions of all the OmniSwitch 10K user manuals:

- *OmniSwitch 10K Getting Started Guide*

Describes the hardware and software procedures for getting an OmniSwitch up and running. Also provides information on fundamental aspects of OmniSwitch software architecture.
- *OmniSwitch 10K Hardware Users Guide*

Complete technical specifications and procedures for all OmniSwitch 10K chassis, power supplies, fans, and Network Interface (NI) modules.
- *OmniSwitch CLI Reference Guide*

Complete reference to all CLI commands supported on the OmniSwitch. Includes syntax definitions, default values, examples, usage guidelines and CLI-to-MIB variable mappings.
- *OmniSwitch AOS Release 7 Switch Management Guide*

Includes procedures for readying an individual switch for integration into a network. Topics include the software directory architecture, image rollback protections, authenticated switch access, managing switch files, system configuration, using SNMP, and using web management software (WebView).
- *OmniSwitch AOS Release 7 Network Configuration Guide*

Includes network configuration procedures and descriptive information on all the major software features and protocols included in the base software package. Chapters cover Layer 2 information (Ethernet and VLAN configuration), Layer 3 information (routing protocols, such as RIP and IPX), security options (authenticated VLANs), Quality of Service (QoS), link aggregation, and server load balancing.
- *OmniSwitch AOS Release 7 Advanced Routing Configuration Guide*

Includes network configuration procedures and descriptive information on all the software features and protocols included in the advanced routing software package. Chapters cover multicast routing (DVMRP and PIM-SM), Open Shortest Path First (OSPF), and Border Gateway Protocol (BGP).
- *OmniSwitch Transceivers Guide*

Includes SFP and XFP transceiver specifications and product compatibility information.
- *Technical Tips, Field Notices*

Includes information published by Alcatel-Lucent's Customer Support group.
- *Release Notes*

Includes critical Open Problem Reports, feature exceptions, and other important information on the features supported in the current release and any limitations to their support.

---

# Technical Support

An Alcatel-Lucent service agreement brings your company the assurance of 7x24 no-excuses technical support. You'll also receive regular software updates to maintain and maximize your Alcatel-Lucent product's features and functionality and on-site hardware replacement through our global network of highly qualified service delivery partners.

With 24-hour access to Alcatel-Lucent's Service and Support web page, you'll be able to view and update any case (open or closed) that you have reported to Alcatel-Lucent's technical support, open a new case or access helpful release notes, technical bulletins, and manuals.

Access additional information on Alcatel-Lucent's Service Programs:

Web: [service.esd.alcatel-lucent.com](http://service.esd.alcatel-lucent.com)

Phone: 1-800-995-2696

Email: [esd.support@alcatel-lucent.com](mailto:esd.support@alcatel-lucent.com)

# 1 OmniSwitch 10K

The Alcatel-Lucent OmniSwitch 10K (OS10K) is a high capacity, high-performance modular Ethernet LAN switch based on the state-of-the-art Alcatel Operating System (AOS). The OS10K is offered in a ten-slot chassis configuration with 1/10/40-Gigabit Ethernet.

The switch's class-leading low-power consumption, front-to-back cooling, compact form-factor, and all front-accessible components make it a perfect fit for data center applications, as well as a long-term upgrade for legacy core platforms.

## OmniSwitch 10K Availability Features

The switch provides a broad variety of availability features. Availability features are hardware and software-based safeguards that help prevent the loss of data flow in the unlikely event of a subsystem failure. In addition, some availability features allow users to maintain or replace hardware components without powering off the switch or interrupting switch operations. Combined, these features provide added resiliency and help ensure that the switch is consistently available for day-to-day network operations.

Hardware-related availability features include:

- [Hardware Redundancy](#)
- [Smart Continuous Switching](#)
- [Hot Swapping](#)
- [Hardware Monitoring](#)
- [Power Checking Sequence](#)

### Hardware Redundancy

- Chassis Management Modules (CMMs)
- Switching Fabric
- Power Supplies
- Fan Units
- MAC EEPROM

For detailed information on CMM redundancy, refer to [Chapter 3, “Chassis Management and Fabric Modules.”](#) For information on power supply and fan redundancy, refer to [Chapter 2, “Chassis and Power Supplies.”](#)

## Smart Continuous Switching

In redundant CMM configurations, the switch provides support for NIs during failover. In other words, if the primary CMM fails or goes offline for any reason, NI modules will continue data transmission and routing functions during the secondary CMM's takeover process. This availability feature is referred to as *Smart Continuous Switching*.

Incoming Layer 2 packets will continue to be sent to the appropriate egress port during failover. Known routes will also be supported. (Note, however, that the NI cannot learn new routes without CMM support. Any new route information will be ignored.) Spanning Tree will continue handling BPDUs received on the switch ports, as well as port link up and down states. The Spanning Tree topology will not be disrupted.

---

**Note.** Smart Continuous Switching is designed to maintain data flow only during CMM failover and is *not* intended to support long-term data flow. If both the primary and secondary CMM modules go offline or are removed from the chassis, switch operations (including all NI support) will be disabled.

---

## Hot Swapping

Hot swapping refers to the action of adding, removing, or replacing certain hardware components without powering off your switch and disrupting other components in the chassis. This feature greatly facilitates hardware upgrades and maintenance and also allows you to easily replace components in the unlikely event of hardware failure. The following hardware components can be hot swapped:

- Chassis Management Modules (CMMs)
- Gigabit Ethernet Network Interface modules (GNIs)
- 10Gigabit Ethernet Network Interface modules (XNIs)
- Power supplies
- Fan trays

---

**Note. Hot Swapping Non-Redundant Management Modules and Power Supplies.** If there is only one CMM or power supply installed in the chassis and either of these components is removed or replaced, all switch functions will stop until a replacement is installed.

---

For information on adding and removing CMMs and CFMs, refer to [Chapter 3, “Chassis Management and Fabric Modules.”](#) For information on adding and removing NIs, refer to [Chapter 4, “Network Interface \(NI\) Modules.”](#) For information on adding and removing power supplies and fan trays, refer to [Chapter 2, “Chassis and Power Supplies.”](#)

---

**Note.** Network Interface (NI) modules can only be hot swapped with like modules. For example, a OS10K-GNI-C48E must be hot swapped with another OS10K-GNI-C48E module and cannot be hot swapped with any other module type. Refer to product release notes for additional guidelines on hot swapping Network Interface (NI) modules.

---

## Hardware Monitoring

### Automatic Monitoring

Automatic monitoring refers to the switch's built-in sensors that automatically monitor operations. The majority of automatic monitoring is provided by the CMM. If an error is detected (e.g., over-threshold temperature), the CMM immediately sends a trap to the user. The trap is displayed on the console in the form of a text error message. (In the case of an over-threshold temperature condition, the CMM displays an amber TEMP LED in addition to sending a trap.)

### LEDs

LEDs, which provide visual status information, are provided on the CMM, NI, and power supply front panels. LEDs are used to indicate conditions, such as hardware and software status, temperature errors, link integrity, data flow, etc. For detailed LED descriptions, refer to the corresponding hardware component chapter (e.g., "Network Interface (NI) Modules").

### User-Driven Monitoring

User-driven hardware monitoring refers to CLI commands that are entered by the user in order to access the current status of hardware components. The user enters "show" commands that output information to the console. The Show commands for all the features are described in detail in the *OmniSwitch CLI Reference Guide*.

## Power Checking Sequence

The power checking sequence is another built-in availability feature. This feature helps regulate power in the switch whenever the switch is booted or an NI module is installed in the chassis.

The sequence is a joint effort between the CMM, the NI modules, and the power supplies. During the boot sequence, the primary CMM automatically compares the power consumption required by installed NIs with the power available from the power supplies. If there is not adequate power to support all NIs, the CMM will power on only the supported number of NIs, starting from the first NI slot position.

---

**Important.** During the power checking sequence, CMMs receive priority and are always powered on. NI modules are then powered on sequentially by slot position. In other words, the NI in slot 1 is powered on, then slot 2, then slot 3, etc. For information on slot positions, refer to [Chapter 2, "Chassis and Power Supplies."](#)

---

### Installing a New NI into a Running Chassis

When an NI module is installed in the chassis, only a small portion of the circuitry is initially powered up. The CMM immediately reads the incoming module's ID and determines how much power the module will require. If the number of power supplies installed in the chassis can provide sufficient power, the CMM turns on the incoming module. If the number of installed power supplies cannot provide sufficient power, the incoming NI will remain powered of





# 2 Chassis and Power Supplies

This chapter includes detailed information on the OmniSwitch 10K chassis, as well as fan tray and power supply components. Topics include:

- Technical specifications, [page 2-3](#).
- Switch mounting information, [page 2-5](#).
- Power supplies and power supply redundancy, [page 2-11](#).
- Temperature management, [page 2-24](#).
- Chassis fan tray on [page 2-27](#).
- Monitoring the chassis components via the Command Line Interface (CLI), [page 2-27](#).

---

**Note.** Detailed information on Chassis Management Modules (CMMs), Chassis Fabric Modules (CFMs) and Network Interface (NI) modules can be found later in this guide.

---

# OmniSwitch 10K Chassis

The OmniSwitch 10K offers eight slots for high-capacity 1/10/40-Gigabit Ethernet Network Interface (NI) modules. Additional slots are used for primary and redundant Chassis Management Modules (CMMs), Chassis Fabric Modules (CFMs), fan trays and power supplies.

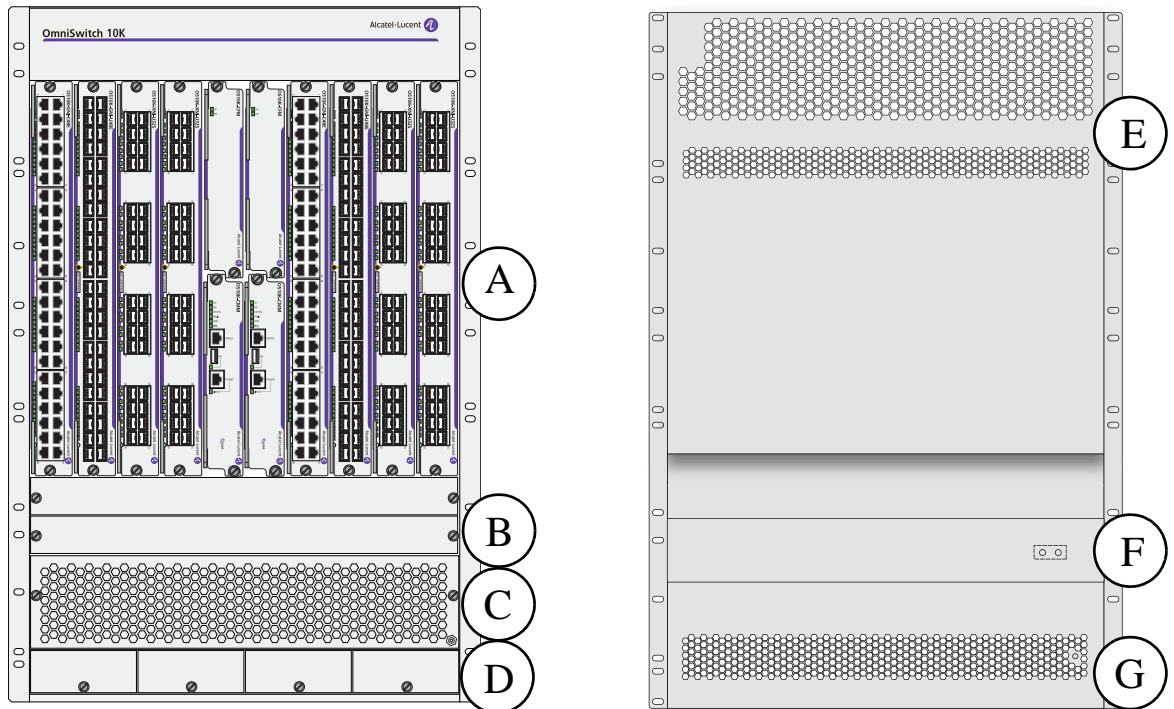

Item	Description
A	<b>Module Slots</b> Provides eight NI module slots, two CMM module slots and two CFM module slots.
B	<b>Fan Trays</b>
C	<b>Air Intake Vent</b>
D	<b>Power Supply Slots</b>
E	<b>Air Exhaust Vent</b>
F	<b>Chassis Grounding Lug</b>
G	<b>Power Supply Fan Exhaust Vent</b>

<b>OmniSwitch 10K Chassis Specifications</b>	
Network Interface Module Slots	8
Chassis Management Module Slots	2
Fabric Module Slots	2
Power Supply Bays	4
Fabric Redundancy	3 + 1
Ambient Temperature (Tmra)	Operating: 0°C to 45°C (32°F to 113°F)
Temperature Danger Threshold	73°C
Chassis Width	19 inches (48.3cm) 17.4 inches (44.2cm) (without rack-mount flanges)
Height	28 inches (71.2 cm or 16 RU)
Overall Depth	23.5 inches (59.7 cm)
Chassis Weight (empty)	approx. 46 pounds (20.9 kg)
Chassis Weight (fully populated)	approx. 198 pounds (89.8 kg)

## Chassis Slot Numbering

The term “slot” refers to the specific position in the chassis where components are installed. OmniSwitch 10K slots are laid out as follows:

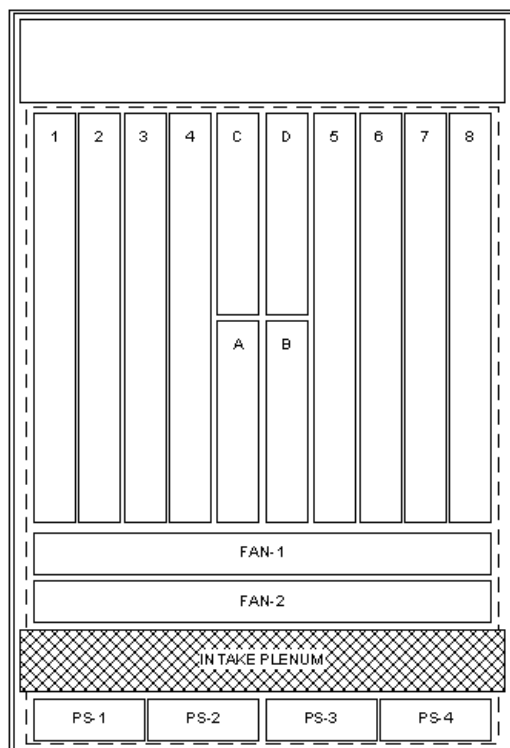

<b>Slot</b>	<b>Component</b>
1 - 8	NI Slots
A - B	CMMs
C - D	CFMs
FAN 1 - 2	Fan Trays
PS 1 - 4	Power Supplies

## **OmniSwitch 10K Slot Numbering**

# Mounting the Switch

## Lifting the Chassis

Due to its weight, lifting the OmniSwitch 10K chassis improperly can cause personal injury and/or damage to the unit. When lifting or moving the chassis, please follow these important guidelines:

- Two people are required when lifting the chassis.
- Do not move a populated switch chassis. Be sure to remove all modules, fan trays and power supplies and set them aside before lifting.
- When lifting the chassis use the recessed hand grip provided on the rear panel and the reinforced area immediately under the front air intake plenum. Refer to the diagram below for more information.

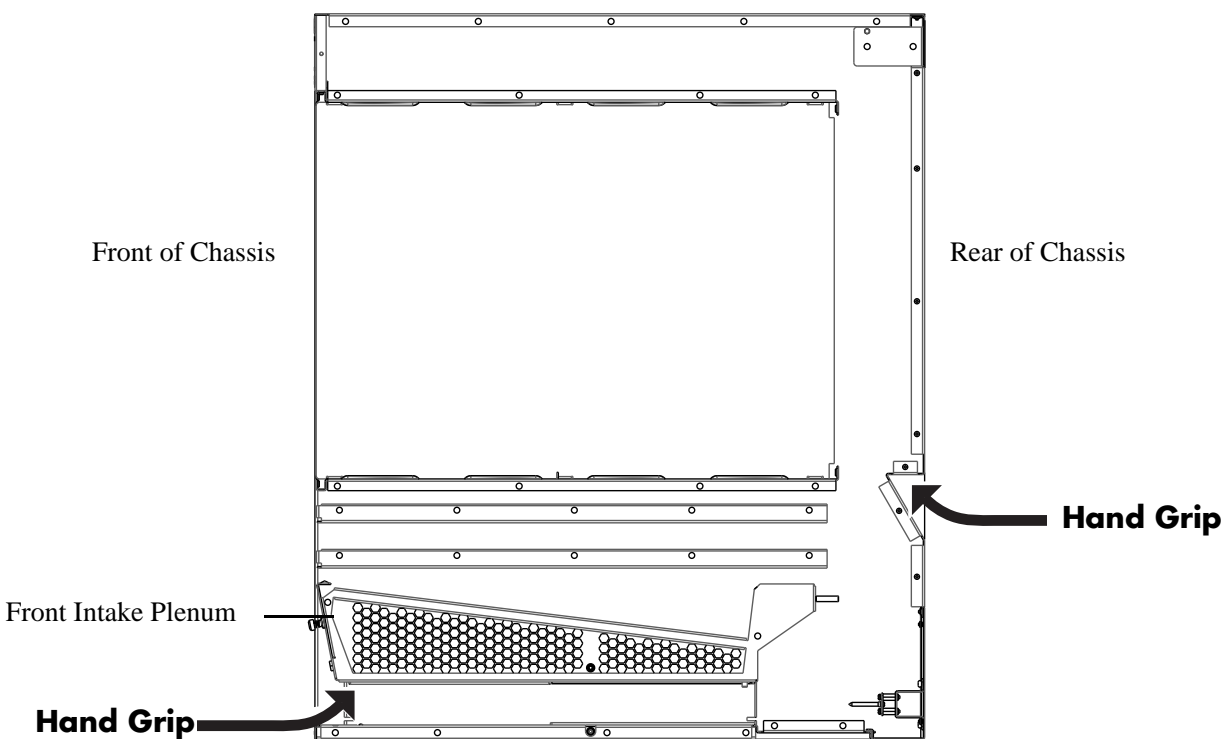

---

**Important.** Due to its weight and airflow requirements, the OmniSwitch 10K cannot be wall-mounted.

---

## General Mounting Recommendations

**Elevated Operating Ambient Temperature.** If installed in a closed or multi-rack assembly, the operating ambient temperature of the rack environment may be greater than the room's ambient temperature. Therefore, consideration should be given to the maximum rated ambient temperature ( $T_{mra}$ ) specified on [page 2-3](#).

**Reduced Air Flow.** Installation of the equipment in a rack should be such that the amount of air flow required for safe operation of the equipment is not compromised. Refer to "[Airflow Recommendations](#)" on [page 2-7](#) for more information.

**Mechanical Loading.** Mounting of the equipment in the rack should be such that a hazardous condition is not achieved due to uneven loading.

**Circuit Overloading.** Consideration should be given to the connection of the equipment to the supply circuit and the effect that overloading of circuits could have on overcurrent protection and supply wiring. Appropriate consideration of equipment nameplate ratings should be used when addressing this concern.

**Reliable Earthing.** Reliable earthing of rack-mounted equipment should be maintained. Particular attention should be given to supply connections other than direct connections to the branch (e.g., use of power strips).

## Airflow Recommendations

To ensure proper airflow, be sure that your switch is placed in a well-ventilated area and provide minimum recommended clearance at the front, back and sides of the switch, as shown below. Restricted airflow can cause your switch to overheat, which can lead to switch failure.

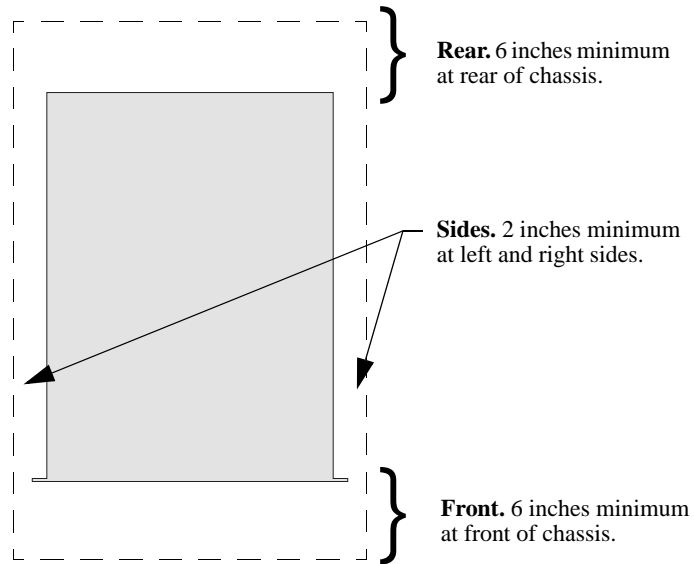

**Chassis Top View**

---

**Note.** Clearance is not required at the top and bottom of the chassis.

---

OmniSwitch 10K fan trays draw air from the intake vents located at the bottom-front and left and right sides of the chassis. The air is directed up through the chassis' module compartment and past the CMM, CFM and NI circuit boards. Airflow is then exhausted through the vent at the top-rear of the chassis.

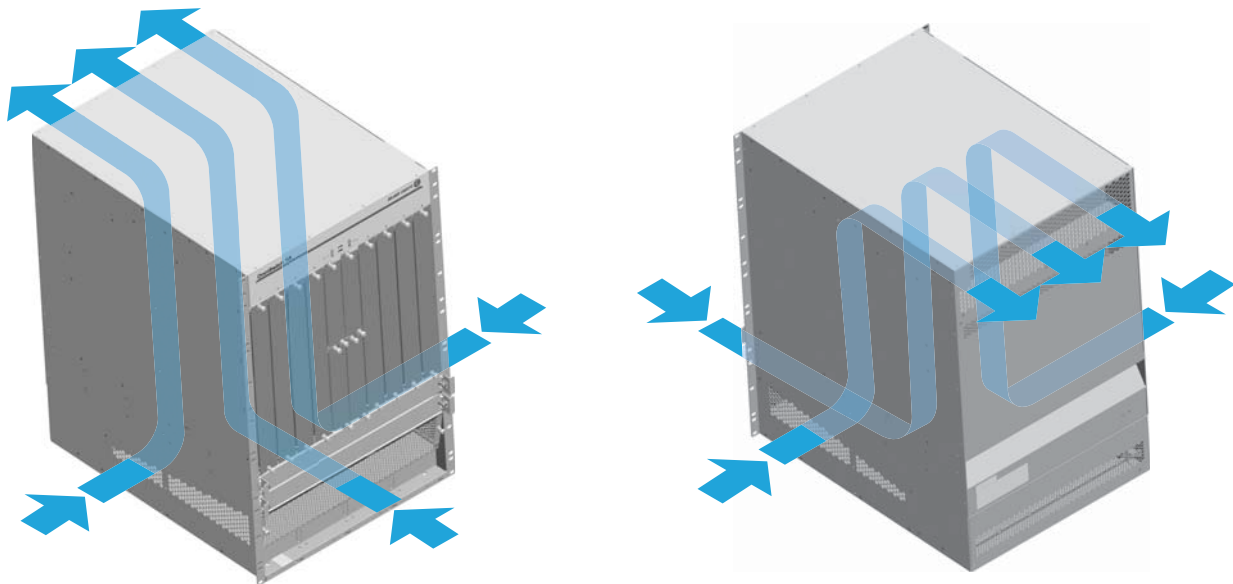

**Chassis Front View**

**Chassis Rear View**

## Blank Cover Panels

Blank cover panels are provided with your switch and are used to cover empty CMM, CFM and NI slots as well as empty power supply bays. These cover panels play an important role in chassis airflow and temperature management. If your switch is not fully populated and blank cover panels are not installed over empty slot locations, airflow is affected.

When blank cover panels are missing, air does not take the direct route from the air intake vents, up through the chassis module compartment, and out through the exhaust plenum as intended. Instead, a portion of the airflow is allowed to escape through the front module compartment of the chassis. As a result, normal airflow is disrupted and an extra task is placed on the fan trays to cool the chassis.

Cover panels also provide protection for module processor boards and other sensitive internal switch components by closing off a chassis that is not fully populated.

---

**Note.** Because they regulate airflow and help protect internal chassis components, blank cover panels should be installed over empty module slots and power supply bays at all times.

---

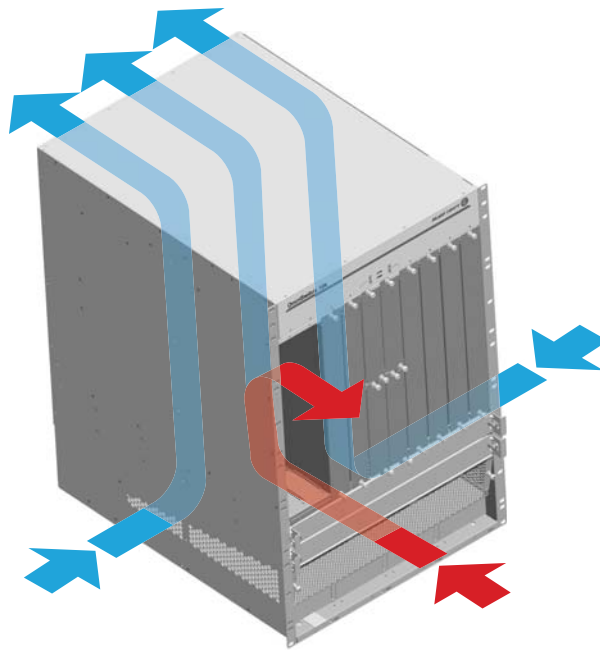

**Effects of Missing Blank Panels on Chassis Airflow**



# Rack-Mounting

Refer to the following important guidelines before installing the chassis in a rack:

- Three people are required to rack mount the switch: Two people to lift the chassis into position and one person to secure the chassis to the rack using the rack mount screws.
- The chassis has two integral rack-mount flanges that support standard 19-inch rack mount installations.
- Alcatel-Lucent does not provide rack-mount screws. Use the screws supplied by the rack vendor.
- To prevent a rack from becoming top heavy, it is recommended that you install the switch at the bottom of the rack whenever possible.
- If you are installing the switch in a relay rack, be sure to install and secure the rack per rack manufacturer's specifications.

---

**Note.** Due to its weight and airflow requirements, the OmniSwitch 10K cannot be wall-mounted.

---

To rack mount the switch, follow the steps below.

- 1** Mark the holes on the rack where the chassis is to be installed.
- 2** Using two people, lift and position the chassis until the rack-mount flanges are flush with the rack post. Refer to [page 2-5](#) for information on properly lifting the chassis.
- 3** Align the holes in the flanges with the rack holes marked in step 1.
- 4** Once the holes are aligned, use a third person to insert a screw through the *bottom hole on each flange*. Tighten both screws until they are secure.
- 5** Once the screws at the bottom of each flange are secure, install the remaining screws. Be sure that all screws are securely tightened.

## Optional Rack-Mounting Hardware

All OmniSwitch 10K switches are shipped with integral front rack mount flanges. These flanges support standard 19" rack mount installations. If you have non-standard rack mount requirements, contact your Alcatel-Lucent representative for information on optional hardware availability.

## Standalone (Non-Rack Mounted) Installations

The chassis can also be placed unmounted on a stable, flat surface as a standalone unit. Be sure that the surface can accommodate the full, populated weight of all switches being installed. Approximate chassis weights are provided on [page 2-3](#).

For a standalone unit, use two or more people to move and position the unpopulated chassis upright on the surface where it is to be installed. Be sure that adequate clearance has been provided for chassis airflow and that you have placed the chassis within reach of all required AC outlets. For recommended airflow allowances, refer to [page 2-7](#).

---

**Note.** Chassis must be placed “right side up.” Never attempt to operate a switch while it is lying on its side or back.

---

# Power Supplies

## OS10K-AC-2500

The power supplies are installed in the slots at the bottom of the switch chassis. See the slot diagram on [page 2-3](#) for more information.

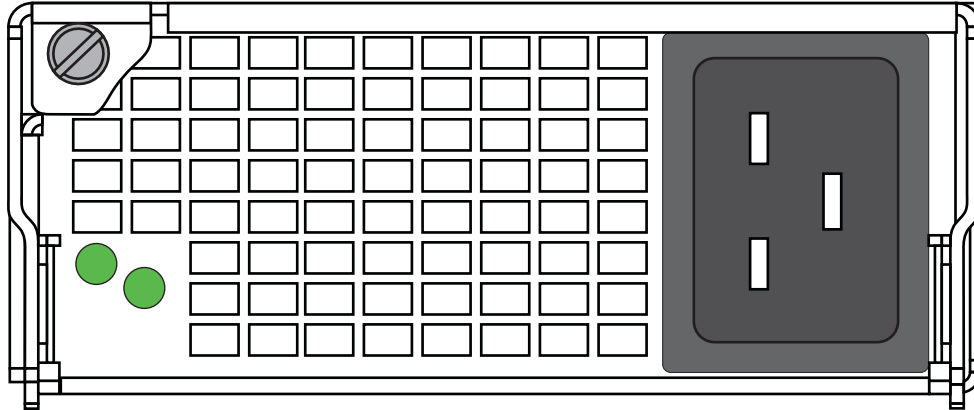

**AC Power Supply Front Panel**

<b>OS10K-AC-2500</b>	
Model	OS10K-AC-2500
Product Compatibility	OmniSwitch 10K
Input Voltage	180 to 264 VAC
Switching Frequency	200kHz (primary); 400kHz (primary);
Input Current	16A @ 180VAC
Output Power	2500W @ 180-264 VAC 1200W @ 90-132 VAC
Output Voltage Range	10.8V to 13.2Vdc
Output Current	208A @ 12V
Operating Temperature	-10 – 70 degrees Celsius (operating)

## OS10K-DC-2400

The DC power supplies are installed in the power supply bays of the chassis. See [page 2-3](#) for a slot diagram showing the power supply bays. See [page 2-3](#) for a slot diagram showing the power supply bays.

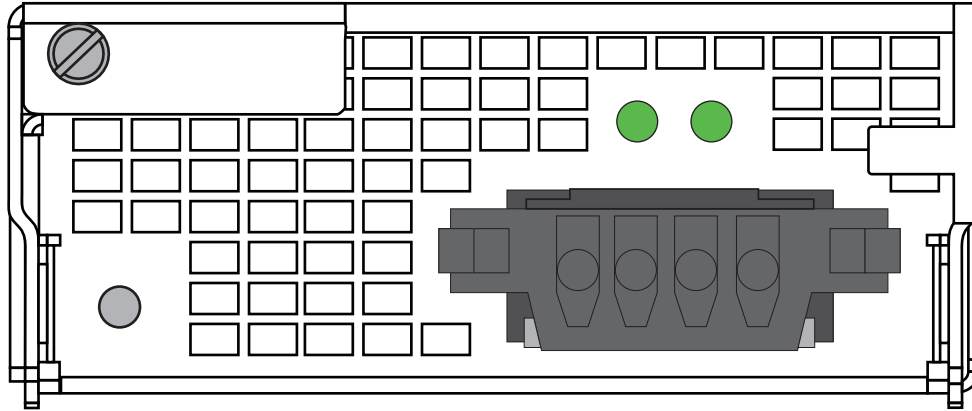

**DC Power Supply Front Panel**

<b>OS10K-DC-2400</b>	
Model	OS10K-DC-2400
Provides Chassis Power For:	OmniSwitch 10K
Input Voltage	-36Vdc to -75Vdc
Output Power	2400W
Ambient Temperature	-10 – 70 degrees Celsius (operating) -40 – 85 degrees Celsius (non-operating)
Humidity	30% to 95% Relative Humidity (Operating) 10% to 95% Relative Humidity (Storage)

## DC Power Supply Connection

### Connecting a DC Cable Harness to the Chassis Power Supply

When plugging in the cable, insert the connector end of the cable harness into the power supply connector until it clicks firmly into place. This is an indication that the connector is secure and properly seated.

### Connecting a DC Cable Harness to the DC Power Source

The other end of the cable harness is bare. Users must assemble and connect this end to the DC power source or to a cable coming from the power source. In addition to following the important guidelines listed below, be sure to consult specifications for the DC power source more information.

- Connect the power supply to a reliably grounded 48V or 60V SELV source.
- The branch circuit overcurrent protection must be rated 75A.
- Use two 10 AWG copper conductors.
- A readily accessible disconnect device that is suitably approved and rated shall be incorporated in the field wiring.
- The above product(s) shall be installed in a restricted access location.
- The power supply shall used with an 4P PWRBLADE CONNECTOR, FCI model 10080598-2ED0006LF.

## Power Supply Redundancy

### 120V Applications

When running at 120V, available redundancy (N+1) is dependent on the number and types of components installed and operating in the switch chassis. The following chart provides basic guidelines. Refer to power budget guidelines on [page 2-15](#) for additional details.

120V Power Source	
PS1	Supports basic switch operation
PS2	Supports basic switch operation; may provide redundancy based on chassis configuration
PS3	Supports basic switch operation; may provide redundancy based on chassis configuration
PS4	Supports basic switch operation; may provide redundancy based on chassis configuration

### 240V Applications

When running at 240V, available redundancy (N+1) is dependent on the number and types of components installed and operating in the switch chassis. The following chart provides basic guidelines. Refer to power budget guidelines on [page 2-15](#) for additional details.

240V Power Source	
PS1	Supports basic switch operation
PS2	Supports basic switch operation; may provide redundancy based on chassis configuration
PS3	Supports basic switch operation; may provide redundancy based on chassis configuration
PS4	Supports basic switch operation; may provide redundancy based on chassis configuration

### DC Applications

When running DC Power, available redundancy (N+1) is dependent on the number and types of components installed and operating in the switch chassis. The following chart provides basic guidelines. Refer to power budget guidelines on [page 2-15](#) for additional details..

DC Power Source	
PS1	Supports basic switch operation
PS2	Supports basic switch operation; may provide redundancy based on chassis configuration
PS3	Supports basic switch operation; may provide redundancy based on chassis configuration
PS4	Supports basic switch operation; may provide redundancy based on chassis configuration

# Chassis Power Budget

## Checking Chassis Power Before Adding Components

Adding Network Interface (NI) modules and other components, as well as removing power supplies, significantly affects the overall power budget for the switch. As soon as a component is inserted and the component's connectors make contact with the chassis backplane, the additional power requirements take effect. If there is not adequate power, the incoming component will not power on. Additional power errors may also occur, which can interrupt data flow on the switch. Therefore, it is important to manually check the current chassis power before adding a module to verify that the current chassis power supports the change.

Use the show chassis command to determine available power budget.

Refer to the table below for component power requirements:

Module being added to chassis	Additional watts needed
OS10K-CMM	81 W
OS10K-CFM	46 W (per CFM added)
OS10K-GNI-C48E	152 W (per module added)
OS10K-GNI-U48E	154 W (per module added)
OS10K-XNI-U32S	432 W (per module added)
OS10K-XNI-U16E	225 W (per module added)
OS10K-XNI-U16L	225 W (per module added)
OS10K-XNI-U32E	424 W (per module added)
OS10K-QNI-U4E	218 W (per module added)
OS10K-QNI-U8E	396 W (per module added)
OS10K-FAN-TRAY	527 W

Refer to the table below for effects of removing power supplies on overall power budget:

Power supply being removed from chassis	Reduction of available power
OS10K-AC-2500	2500W @ 180-264 VAC (per PS removed) 1200W @ 90-132 VAC (per PS removed)
OS10K-DC-2400	2400 W (per PS removed)

## Installing Power Supplies

**1** Orient the power supply so that the power cord socket is situated at the right of the power supply. Also, for the power supply to seat properly, make sure that the handle is in the open (horizontal) position as shown.

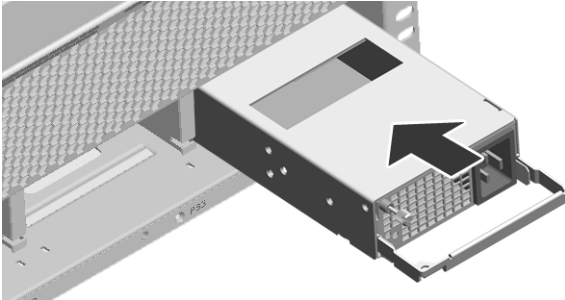

**2** Slide the power supply back until its connector meets the chassis backplane.

**3** When the power supply is fully seated, rotate the handle 90 degrees to the closed (vertical) position.

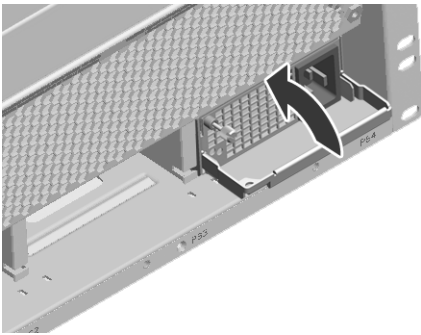

**4** Tighten the captive screw, located at the top-left of the power supply's front panel.

**5** Plug the power cord (provided) into the power supply's socket.

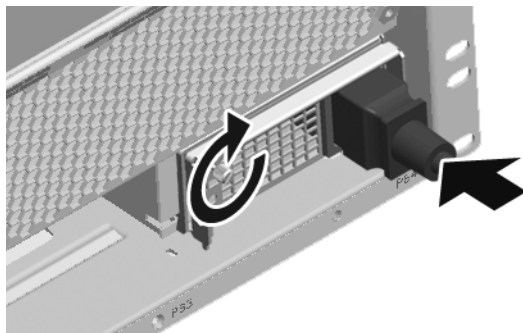



- 6 Align as shown and place the cord retainer assembly against the front panel of the power supply.

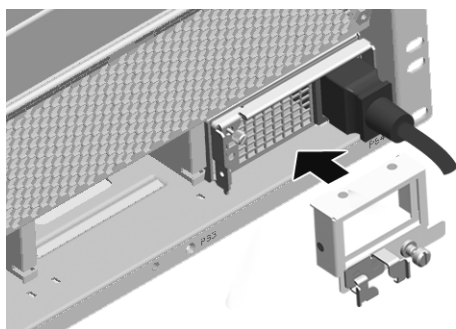

- 7 Secure the bracket to the bottom rail of the chassis using the captive screw and then route the power cord through the retainer bracket as shown.

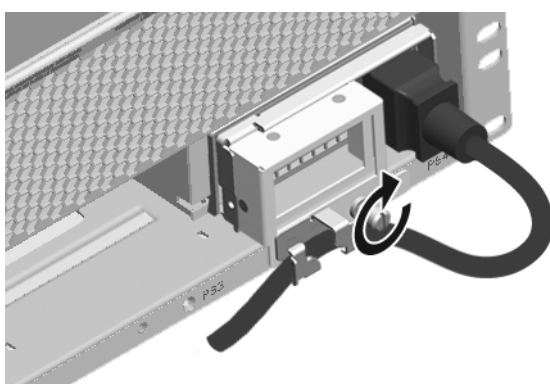

---

**Note.** Connecting a the power supplies to a power source at this time will boot the chassis.

---

## Removing a Power Supply

- 1 Before removing a power supply, unplug the power cord from its power source.
- 2 Free the power cord from the cord retainer clip and remove the cord retainer assembly from the power supply by loosening the captive screw.

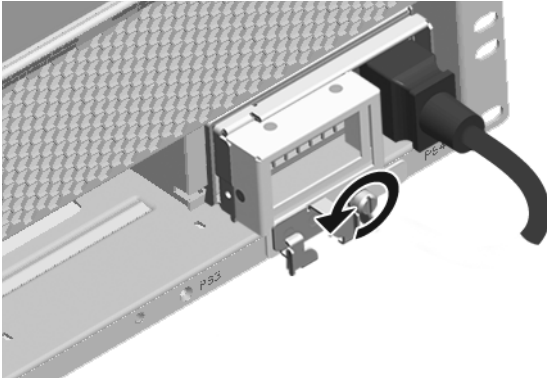

- 3 Unplug the power cord from the power supply socket.

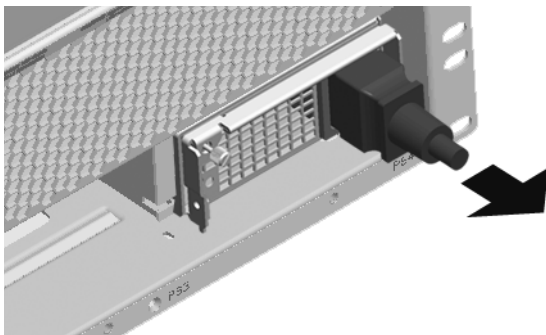

- 4 Loosen the captive screw, located at the top-left of the power supply's front panel.
- 5 Rotate the handle 90 degrees to the open (horizontal) position.

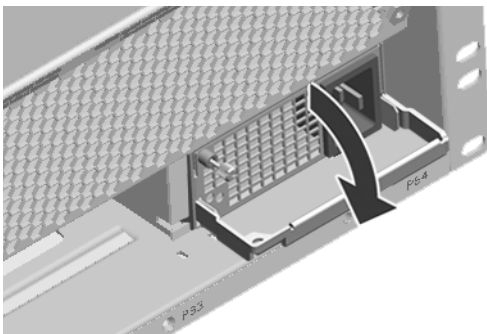

- 6 Slide the power supply out of the power supply bay.

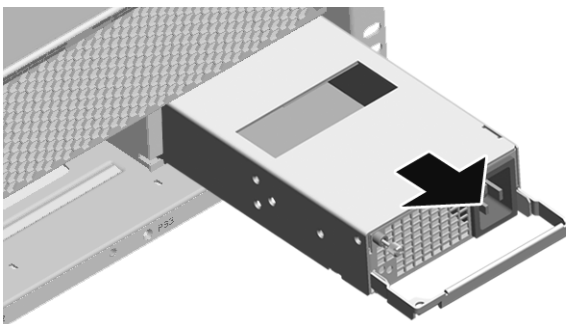

---

**Note.** If you are not replacing the power supply, be sure to install a blank cover panel over the empty power supply bay. To install a blank cover panel, fasten the panel to the bottom rail of the chassis using the captive screw.

---

## Chassis Fan Trays

The OmniSwitch 10K chassis houses two fan trays each with independently-operating fans. The fan trays are the main temperature control components for the switch, providing cooling airflow for all chassis components. This airflow is a crucial factor in the switch's overall operability. Refer to [“Airflow Recommendations” on page 2-7](#) for more information

---

**Important.** Fan trays are required components. Never attempt to operate the switch without fan trays installed.

---



**OmniSwitch 10K Chassis Fan Tray**

---

### Fan Tray Technical Specifications

---

Power	527 W
Number of fans per tray	12

---

**Note.** When two fan trays are installed in the chassis, fans run at variable speeds based on detected changes in ambient room temperature and chassis temperature (caused by normal switch operations). However, if only one fan tray is installed in the chassis, all fans run at maximum speed. Fans may also run at higher speeds after a reboot but will adjust as necessary after approximately 5 minutes.

---

## Removing Fan Trays

- 1 Begin by loosening the two captive screws located at the left and right sides of the tray's front panel.

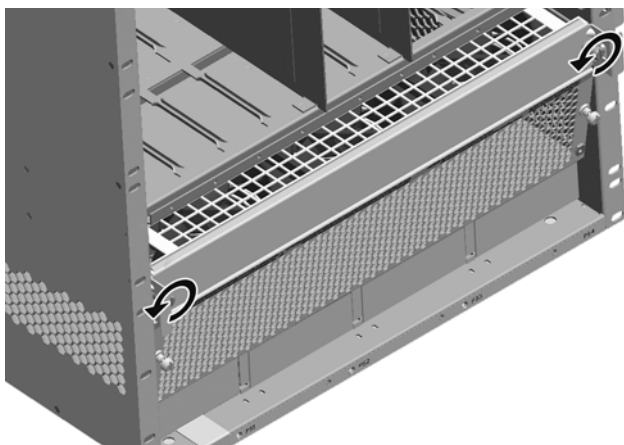

- 2 Pull the fan tray straight out of the chassis.

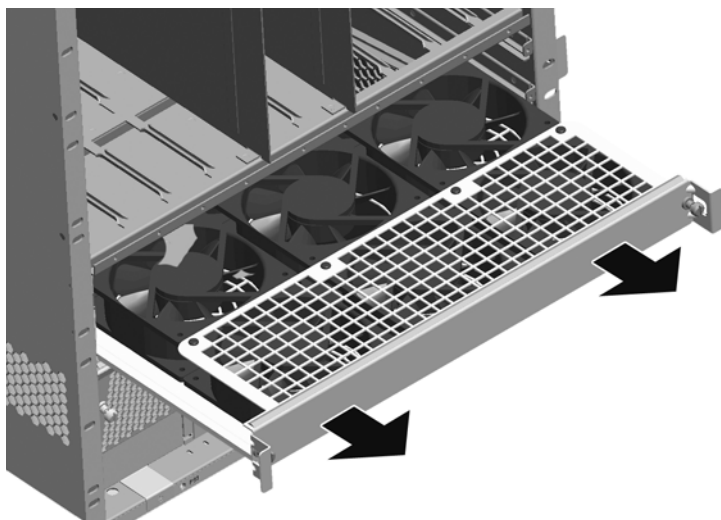

## Installing Fan Trays

- 1 Insert the tray into the chassis slot and slide it straight back until it meets the chassis backplane connectors.

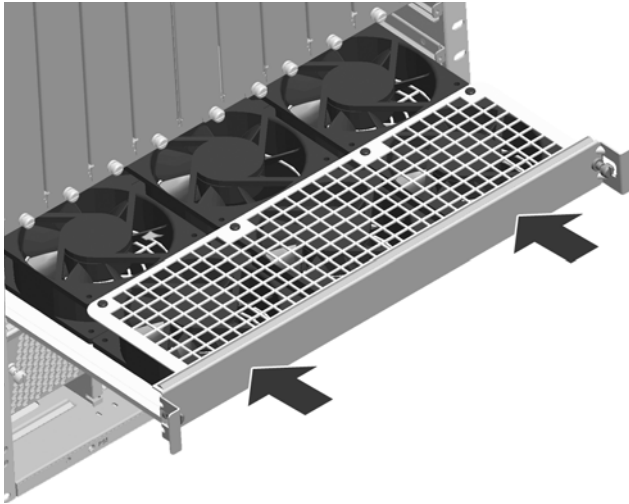

- 2 When the fan tray is firmly seated in the chassis, tighten the two captive screws at the left and right sides of the fan tray's front panel.

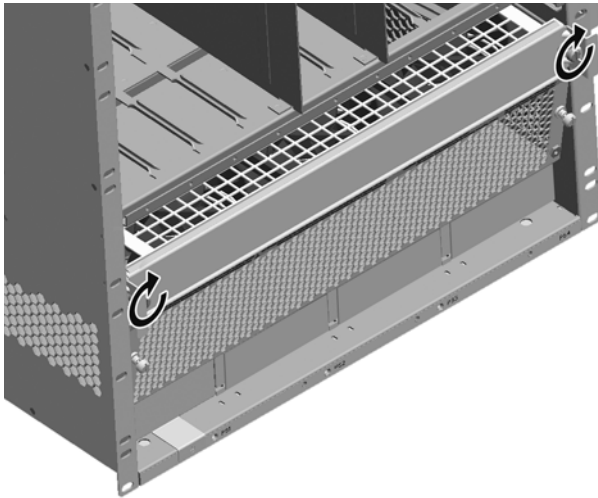

## Grounding the Chassis

The switch has two threaded holes for grounding screws located on the rear of the chassis. These holes use 10-32 screws and are surrounded by a small paint-free rectangular area, which provides metal-to-metal contact for a ground connection.

Use this connector to supplement the ground provided by the AC power cord. To do so, install a Panduit Grounding Lug (type LCD8-10A-L) using 8AWG copper conductors to the paint-free rectangular area.

Refer to the rear chassis view on [page 2-2](#) for location details.

# Monitoring Chassis Components

## Viewing Chassis Slot Information

To view basic slot information, enter the show module command at the CLI prompt:

```
-> show module
```

Slot	Part-Number	Serial #	HW Rev	Mfg Date	Model Name
CMM-A	543212345	123454321	123	Jan 20 2010	OS10-CPM
CMM-B	543212345	123454321	123	Jan 20 2010	OS10-CPM
SLOT-1	543212345	123454321	123	Jan 20 2010	OS10-GNI-C48
SLOT-3	543212345	123454321	123	Jan 20 2010	OS10-GNI-C48
SLOT-4	543212345	123454321	123	Jan 20 2010	OS10-GNI-C48

To view more detailed information, use the show module long command:

```
-> show module long
```

```
Module in slot CMM-A
```

```
Model Name: OS10-CPM,
Description: CMM,
Part Number: 543212345,
Hardware Revision: 123,
Serial Number: 123454321,
Manufacture Date: Jan 20 2010,
FPGA - Physical 1: Dec. 24 2009,
Admin Status: POWER ON,
Operational Status: UP,
Max Power: 0,
Power Consumption: 888,
CPU Model Type : MPC8572 Motorola,
MAC Address: 00:d0:95:ab:ad:13,
```

```
Module in slot CMM-B
```

```
Model Name: OS10-CPM,
Description: CMM,
Part Number: 543212345,
Hardware Revision: 123,
Serial Number: 123454321,
Manufacture Date: Jan 20 2010,
FPGA - Physical 1: Dec. 24 2009,
Admin Status: POWER ON,
Operational Status: DOWN,
Max Power: 0,
Power Consumption: 888,
CPU Model Type : MPC8572 Motorola,
MAC Address: 00:d0:95:ab:ad:13,
```

*Additional output not shown.*



# Monitoring Chassis Temperature

The operating temperature of your switch is a critical factor in its overall operability. In order to avoid a temperature-related system failure, your switch must always run at a temperature within the specified operating temperature range. Refer to the [page 2-3](#) for more information.

To avoid chassis over-temperature conditions, follow the important chassis airflow recommendations on [page 2-7](#).

---

**Monitoring Chassis Temperature Status.** To check the switch's current temperature status, use the **show temperature** command. For example:

```
-> show temperature
Device | Current | Range | Danger | Thresh | Status
-----+-----+-----+-----+-----+-----
CMAA   45      15-73  73      68      UNDER THRESHOLD
CMMA   45      15-73  73      68      UNDER THRESHOLD
FABA   46      15-73  73      68      UNDER THRESHOLD
Slot1  43      15-73  73      68      UNDER THRESHOLD
Slot3  43      15-73  73      68      UNDER THRESHOLD
Slot4  43      15-73  73      68      UNDER THRESHOLD
```

Note: All temperatures are in Celsius.

For more information about this command, see the “Chassis Management and Monitoring Commands” chapter in the *OmniSwitch CLI Reference Guide*.

## Temperature Errors

The CMM monitors the chassis ambient air temperature at all times via an onboard sensor. If an over-temperature condition occurs, there are two different levels of error severity:

- Warning threshold has been exceeded
- Danger threshold has been exceeded

### Warning Threshold

If the temperature exceeds the switch's user-configurable *warning threshold*, the CMM sends out a trap. Traps are printed to the console in the form of text error messages. The CMM's TEMP LED also displays amber, indicating an error. (Refer to [Chapter 2, "Chassis and Power Supplies"](#) for CMM front panel descriptions, including status LEDs.)

When the warning threshold has been exceeded, switch operations remain active. However, it is recommended that immediate steps be taken to address the over-temperature condition.

Addressing warning threshold temperature conditions may include:

- Checking for a chassis airflow obstruction
- Checking the ambient room temperature
- Checking the fan tray status using the [show fan](#) command. See [page 2-27](#) for more information.
- Verifying that the warning threshold has not been manually set to an otherwise common or acceptable ambient temperature—for example, 55 degrees Centigrade. (The default warning threshold is 70C. This value may be configured using the [temp-threshold](#) command. The current set warning threshold may be viewed using the [show temperature](#) command.)

---

**Note.** Once the ambient air temperature is reduced to below the warning threshold, the CMM's TEMP LED automatically resets to green.

---

### Temperature Danger Threshold

If the chassis ambient air temperature rises above the danger threshold (see specifications on [page 2-2](#)) the switch will power off all Network Interface (NI) modules until the temperature conditions have been addressed and the switch is manually booted. The danger threshold is factory-set and cannot be configured by the user.

Addressing danger threshold temperature conditions may include:

- Checking for a chassis airflow obstruction
- Checking the ambient room temperature
- Checking the fan tray status using the [show fan](#) command. See [page 2-27](#) for more information.

---

**Note.** When the danger threshold has been exceeded, the CMM's TEMP LED will not reset from amber to green until after a system boot.

---

## Monitoring Fan Tray Status

The CMM constantly monitors fan operation. If any of the switch's fans unexpectedly shuts down, the CMM sends out a trap and the FAN LED on the CMM's front panel displays amber.

---

**Note.** To check the switch's current fan tray status, use the [show fan](#) command. For example:

---

```
-> show fan
Fan          Status
-----+-----
Fan-1       Running
Fan-2       Running
```

For more information about this command, see the “Chassis Management and Monitoring Commands” chapter in the *OmniSwitch CLI Reference Guide*.

## Fan Tray Redundancy

In the event that one fan tray quits unexpectedly, the remaining fan tray will continue running; switch operations are not disrupted.

---

**Note.** Fan failure needs to be reported immediately in order to make an RMA unit available, and upon receiving the unit, it must be replaced immediately. For information on emergency replacement of the fan tray, refer to [“Removing Fan Trays”](#) above.

---

---

**Storing Backup Fan Trays.** It is a good idea to keep at least one backup fan tray in your data facility.

---



# 3 Chassis Management and Fabric Modules

## Chassis Management Module (CMM)

The Chassis Management Module (CMM) is the management unit for the OmniSwitch chassis. In its role as the management unit, the CMM provides key system services, including:

- Console, USB, and Ethernet management port connections to the switch
- Software and configuration management, including the Command Line Interface (CLI)
- Web-based management (WebView) management
- Power distribution
- Switch diagnostics
- Important availability features, including redundancy (when used in conjunction with another CMM), software rollback, temperature management, and power management

## Chassis Fabric Module (CFM)

The Chassis Fabric Module (CFM) provides expanded switching fabric for the chassis. Data passing from one NI module to another passes through the CFM. Additional CFMs provide increased switching throughput, as well as redundancy.

### CMM and CFM Slot Locations

Slot numbers are clearly marked on the OS10K front panel. In a non-redundant (i.e., single CMM) configuration, the CMM module can be installed in either slot A or slot B of the chassis. For redundant CMM configurations, a CMM module must be installed in both slot A and slot B.

Refer to the diagram on [page 3-9](#) for more information on slot locations. Refer to [page 3-9](#) for more information on CMM redundancy.

CFM modules can be installed in slots C and D. If redundant (dual) CMMs are installed, two CFMs must be installed in order to provide redundancy.

## OS10K-CMM Front Panel

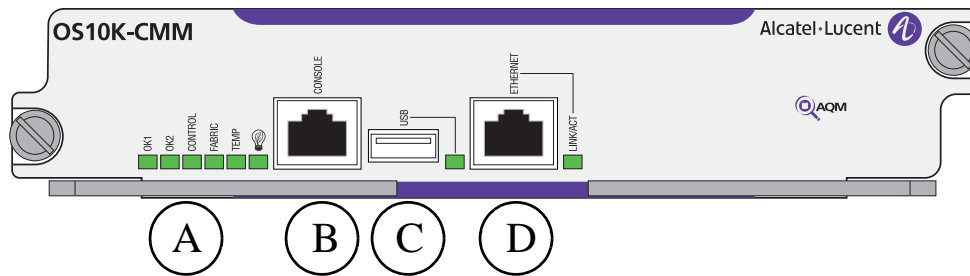

**OS10K-CMM Front Panel**

Item	Description
A	<b>Module Status LEDs</b> Provides status on hardware, software, primary and redundant power. Refer to <a href="#">“CMM/CFM LED Status Indicators”</a> on page 3-4 for LED status information.
B	<b>Console Port</b> RS-232 console port with an RJ-45 connector. Provides access to the CLI for configuration and management.
C	<b>USB Port</b> High speed USB 2.0 port.
D	<b>Ethernet Management Port</b>

### OS10K-CMM Technical Specifications

Power	81 W
-------	------

## OS10K-CFM Front Panel



**CFM Front Panel**

<b>Item</b>	<b>Description</b>
A	<b>Module Status LEDs</b> Provides module status. Refer to <a href="#">“CMM/CFM LED Status Indicators”</a> on page 3-4 for LED status information.

### OS10K-CFM Technical Specifications

Power	46 W
-------	------

## CMM/CFM LED Status Indicators

LED	State	Description
<b>OK1</b>	Green	Passed diagnostics
	Amber	Failed diagnostics
<b>OK2</b>	Green	Operational
	Amber	Transitional state (e.g. downloading code)
<b>Control</b>	Green	CMM Processor is Primary
	Green Blinking	CMM processor is Secondary
	Amber	CMM processor is not functioning correctly
	Amber Blinking	CMM processor upgrade in progress
<b>Fabric</b>	Green	Fabric section is functioning correctly
	Amber	Fabric section is not functioning correctly
<b>Temp</b>	Green	Temperature is 0-40C
	Amber Blinking	Temperature is 40- 45C
	Amber	Temperature is over 45C
	Green	Power save features are active
<b>USB</b>	Green	USB device is mounted
	Green Blinking	USB device is transferring data
<b>LINK/ACT</b>	Green	Ethernet port link is enabled
	Green Blinking	TX or RX activity on Ethernet port



# Installing CMM and CFM Modules

Before installing CMM and CFM modules in the OmniSwitch 10K, locate their slot positions in the chassis. Slot numbers are clearly marked on the OmniSwitch 10K front panel.

CMM modules may be installed in slots A and B. CFM modules may be installed in slots C and D.

---

**Note.** If two CMM modules are installed in a chassis, the CMM occupying slot A is the primary CMM by default.

---

To install an CMM or CFM module, follow the steps below:

**1** Insert the module into the slot along the chassis card guides. The component side of the board should face right. The module should slide in easily.

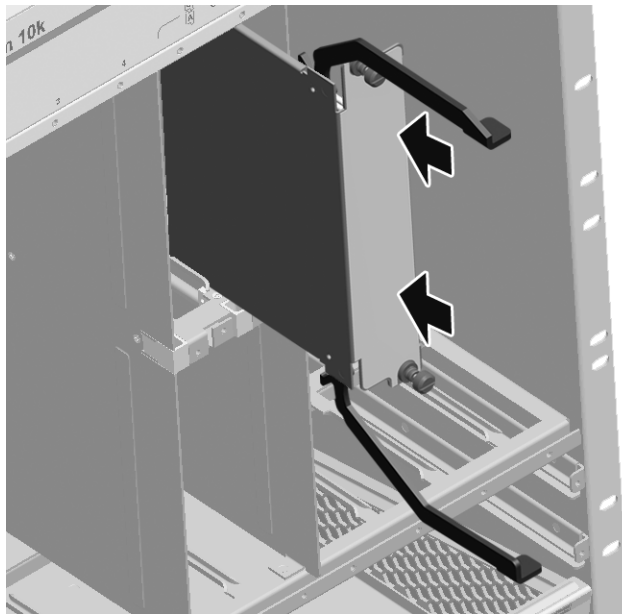

---

**Note.** Do not force the module into the slot. If resistance is encountered, make sure the module is aligned properly in the card guides.

---

**2** When the module is nearly seated in the slot, be sure that the two extractor levers—one on top of the module and one on the bottom—are open (approximately 90 degrees). This allows the notch on each extractor lever to grasp the rail on the chassis.

**3** Once the notches have grasped the rail, use your thumbs to press both extractor levers inward simultaneously until the module is firmly seated. (The bottom lever should overlap the top lever.)

**Caution.** In order to avoid personal injury caused by pinch hazard, be sure to keep hands and fingers clear of the area between the extractor levers as they close.

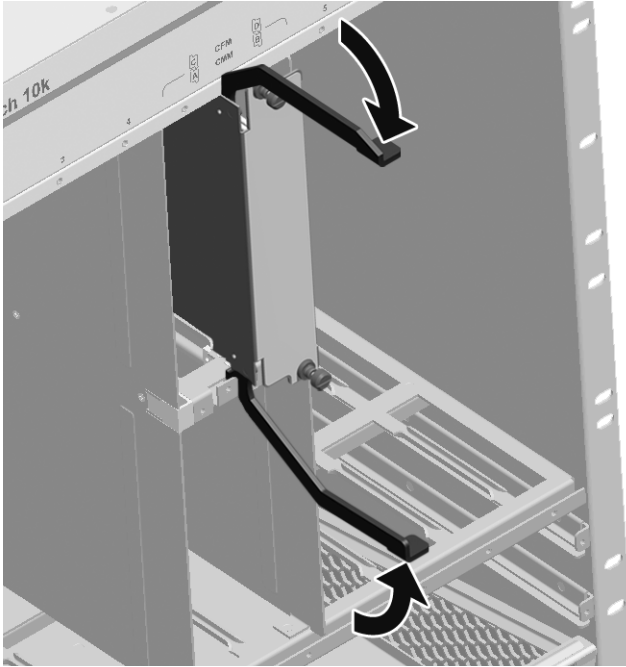

### Caution: Pinch Point Hazard

To avoid personal injury, use thumbs to depress both extractor levers and keep hands and fingers clear of area between levers when installing.

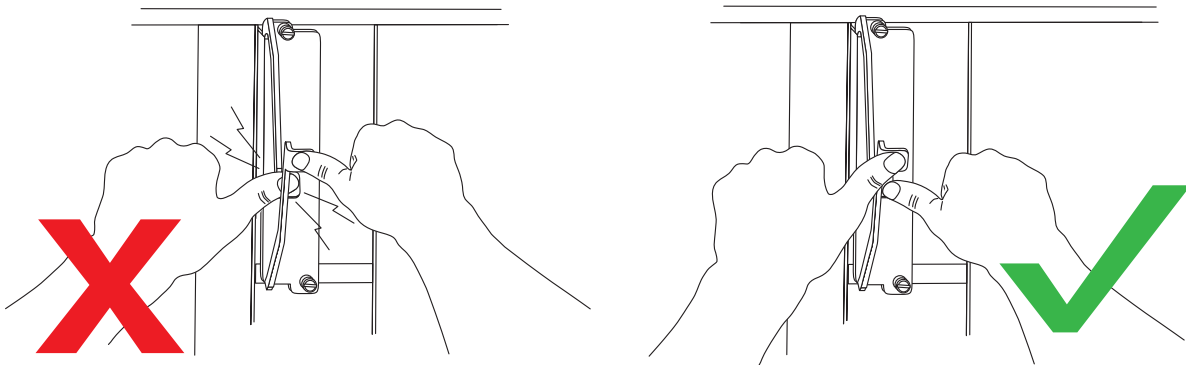

- 4 Once the module is firmly seated, secure the module to the chassis by tightening the captive screws.

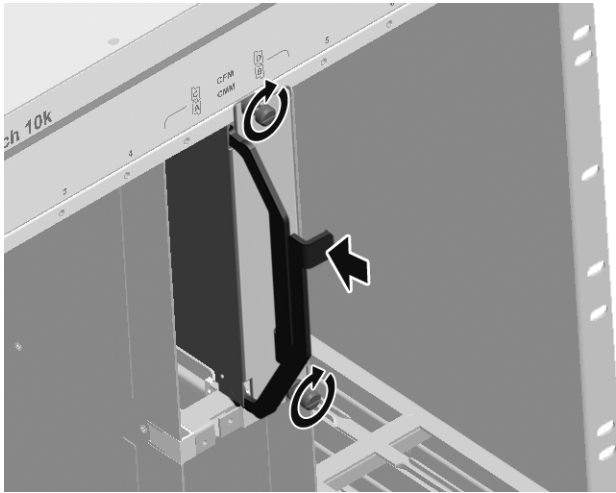

## Console Port

### Serial Connection to the Console Port

The console port, located on the CMM front panel, provides a serial connection to the switch and is required when logging into the switch for the first time. By default, this R-J45 connector provides a DCE console connection.

#### Serial Connection Default Settings

The factory default settings for the serial connection are as follows:

<b>baud rate</b>	9600
<b>parity</b>	none
<b>data bits (word size)</b>	8
<b>stop bits</b>	1
<b>X-ON/X-OFF</b>	enabled

# CMM Redundancy

CMM redundancy is one of the switch's most important failover features. For CMM redundancy, two fully-operational CMM modules must be installed in the chassis at all times. In addition, the software on the two CMM modules must be synchronized. (Refer to [“Synchronizing the Primary and Secondary CMMs”](#) on page 3-9 for more information.)

When two CMMs are running in the switch, one CMM has the primary role and the other has the secondary role at any given time. The primary CMM manages the current switch operations while the secondary CMM provides backup (also referred to as “failover”).

In a redundant configuration, if the primary CMM fails or goes offline for any reason, the secondary CMM is instantly notified. The secondary CMM automatically assumes the primary role.

## CMM Failover Sequence

The figure below illustrates the CMM failover sequence:

- 1 CMM A (installed in the left-hand Slot A position) is operating in the primary mode. CMM B (installed in the right-hand Slot B position) is operating in the secondary mode—i.e., it is functioning as the standby CMM and is ready to take over chassis management functions in the event of a primary CMM failure.
- 2 CMM A fails or is taken offline (e.g., the module is physically removed from the chassis).
- 3 CMM B automatically assumes the primary role.

## Synchronizing the Primary and Secondary CMMs

CMM synchronization refers to the process of copying all files in the flash memory of the primary CMM to the flash memory of the secondary CMM. This ensures that the file directories match exactly on both modules, which prevents the secondary CMM from assuming the primary role with incorrect or outdated software or configuration files in the event of a primary CMM failure.

---

**Important.** In order to have effective CMM redundancy, CMM modules must be synchronized at all times. For detailed information on CMM synchronization and managing flash memory content, refer to the “Managing CMM Directory Content” chapter in the *Switch Management Guide*.

---

# Hot Swapping CMM Modules

Hot swapping a CMM refers to the action of adding, removing, or replacing a CMM module while the switch is operating. You are not required to enter a CLI command in order to hot swap CMM modules. This function can be performed on the fly by simply removing the module from the switch chassis.

## Hot Swap Requirements

### Removing or Replacing CMMs

You must have CMM redundancy before removing or replacing a CMM. If the switch has only one CMM installed and you attempt to hot swap the module, all switch management functions, as well as network data flow, will be terminated.

Also, before removing or replacing the primary CMM in a redundant configuration, verify that the primary and secondary CMM modules are synchronized. Otherwise, data flow and switch management functions may be interrupted due to incorrect or outdated software when the secondary CMM takes over.

Refer to [“CMM Redundancy” on page 3-9](#) and the “Managing CMM Directory Content” chapter in the *Switch Management Guide* for detailed information.

### Adding a Secondary CMM

A secondary (or *redundant*) CMM module can be added to the chassis at any time without disturbing the operation of the switch. However, you should synchronize the primary and secondary CMMs immediately after the hot swap in order to have effective redundancy.

For more information, refer to [“Synchronizing the Primary and Secondary CMMs” on page 3-9](#).

---

**Note.** For detailed instructions on physically installing and removing CMM modules, refer to [“Installing CMM and CFM Modules” on page 3-5](#).

---

# Managing CMM Modules

Refer to the “Managing CMM Directory Content” chapter in the *Switch Management Guide* for detailed information on managing CMM modules.

## Reloading a CMM Module

You can reload either the primary or secondary CMM module using the CLI’s **reload** command. For information on using this command, refer to the “Managing CMM Directory Content” chapter in the *Switch Management Guide*. A CMM reload is essentially a soft boot of the module. Note that you can reload only one CMM module at a time; the primary and secondary CMMs cannot be reloaded simultaneously.

### Reloading the Primary CMM

If the primary CMM is reloaded, the secondary CMM automatically takes over primary management functions. In other words, the secondary CMM becomes the primary CMM as soon as the reload is initiated. The reloaded CMM then assumes the secondary—or *redundant*—role when the reload sequence is complete.

### Reloading the Secondary CMM

If the secondary CMM is reloaded, only the secondary CMM is affected. The primary CMM continues all operations without interruption.

# Monitoring CMM Modules

## Front Panel LEDs

The CMM provides a series of status LEDs on the module's front panel. These LEDs offer basic status information for the following switch functions:

- CMM hardware operation
- System software
- CMM processor status
- CMM fabric status
- Chassis ambient air temperature
- Fan status
- Power Supply Unit (PSU) status
- Ethernet management port

Refer to [“CMM/CFM LED Status Indicators”](#) on page 3-4 for information on CMM front panel LEDs.

## Accessing General CMM Information

The switch's Command Line Interface (CLI) offers CMM monitoring commands. These commands allow you to access general CMM hardware information as well as the current operating status of CMM-related components.

### CMM Hardware Information

The [show cmm](#) and [show hardware info](#) commands are used to display general hardware information for the CMM module(s) installed in the chassis.

Use the **show cmm** command to display the following information:

- Model name and description for each CMM
- Part number and serial number
- Hardware revision level
- Manufacture date
- Firmware version number
- Administrative and operating status
- Additional information, such as power control checksum, ASIC information, and chassis MAC Address.

For a detailed information on the **show cmm** command, including output table descriptions, refer to the *OmniSwitch CLI Reference Guide*.



The **show hardware info** command displays the following information:

- CPU type
- Flash manufacturer and flash size
- RAM manufacturer and RAM size
- NVRAM battery status
- Jumper settings
- BootROM and Miniboot versions
- FPGA version(s)

For detailed information on the **show hardware info** command, including output table descriptions, refer to the *OmniSwitch CLI Reference Guide*.

## Operating Status of CMM-Related Components

The CMM contains the switch's temperature sensor and monitors fan operation. If the TEMP or FAN LEDs on the CMM's front panel indicate an error, you can use the **show temperature** and **show fan** commands to access additional status information.

For information on reading temperature and fan status LEDs, refer to [page 3-4](#).

For information on using the **show temperature** and **show fan** commands, as well as information on temperature management and fan maintenance, refer to [Chapter 2, "Chassis and Power Supplies."](#)

# Chassis Switching Fabric

Because each CMM module contains its own factory-installed fabric board, additional Chassis Fabric Modules (CFMs) are not required for switch operations. However, to provide wire rate bandwidth performance and fabric redundancy, up to two Chassis Fabric Modules (CFMs) can be added. For more detailed information, refer to the section below.

## Fabric Boards and Chassis Bandwidth

In order to operate at full wire rate, OmniSwitch 10K switches must have a minimum of three fabric boards operating at all times.

Each fabric board provides slightly more than 33 percent of wire rate, so three fabric boards provide a full 100 percent of wire rate bandwidth for the chassis. The addition of a fourth fabric board (by installing a redundant CFM module) provides an extra margin of throughput and redundancy.

Each NI module consists of port groups connected by the fabric boards. The following chart outlines performance per port group, based on the number of fabric boards installed.

NI Type	Port Group	One Fabric Board	Two Fabric Boards	Three Fabric Boards	Four Fabric Boards
OS10K-XNI-U32S	Four groups of eight 10Gb ports	Any two ports per group operate at wire rate.	Any five ports per group operate at wire rate.	All ports operate at wire rate.	All ports operate at wire rate.
OS10K-GNI-U48E	One group of 48 GigE ports	Any 26 ports in group operate at wire rate.	All ports operate at wire rate.	All ports operate at wire rate.	All ports operate at wire rate.
OS10K-GNI-C48E	One group of 48 GigE ports	Any 26 ports in group operate at wire rate.	All ports operate at wire rate.	All ports operate at wire rate.	All ports operate at wire rate.

## Pinouts

### RJ-45 Console Port – Connector Pinout

<b>Pin Number</b>	<b>Signals as DTE Console Port</b>
1	NC
2	NC
3	RXD
4	Ground
5	Ground
6	TXD
7	NC
8	NC



# 4 Network Interface (NI) Modules

Several Gigabit Network Interface (GNI) and 10 Gigabit Ethernet Interface (XNI) modules are available for the OmniSwitch 10K switch. GNI and XNI modules come with a variety of port speeds, connector types and features.

## In This Chapter

This chapter provides specifications and descriptions of all modules currently available for the OmniSwitch 10K. Procedures using Command Line Interface (CLI) commands to manage and monitor NI modules are also provided.

Specifications, descriptions, and procedures in this chapter include:

- Specifications and descriptions of GNI modules on [page 4-2](#).
- Specifications and descriptions of XNI modules on [page 4-2](#).
- Specifications and descriptions of QNI modules on [page 4-2](#).
- Procedures for monitoring NI modules on [page 4-6](#).
- Procedures for removing and adding modules on [page 4-12](#).
- Pinouts of RJ-45 ports on 10/100/1000 modules on [page 4-15](#).
- An overview of proper handling of fiber optic cables on [page 4-16](#).

## GNI Modules

Gigabit Ethernet Network Interface (GNI) modules provide 1000 Mbps (1 Gbps) connections. The following GNI modules are available:

- **OS10K-GNI-C48E.** Provides 48 auto-sensing ports, auto-negotiating *and* individually configurable as 10BaseT, 100BaseTX, or 1000BaseT. Refer to [page 4-3](#) for detailed information on this module.
- **OS10K-GNI-U48E.** Provides 48 SFP transceiver connectors. Refer to [page 4-4](#) for information on this module.

## XNI Modules

OmniSwitch 10K 10 Gigabit Network Interface (XNI) modules provide up to 48 10000 Mbps (10 Gbps) connections per module. The following 10 Gigabit modules are available:

- **OS10K-XNI-U32S.** Provides 32 SFP+ transceiver connectors. Refer to [page 4-5](#) for information on this module.
- **OS10K-XNI-U32E.** Provides 32 SFP+ transceiver connectors. Refer to [page 4-6](#) for information on this module.
- **OS10K-XNI-U16E.** Provides 16 SFP+ transceiver connectors. Refer to [page 4-7](#) for information on this module.
- **OS10K-XNI-U16L.** Provides 16 SFP+ transceiver connectors. Refer to [page 4-8](#) for information on this module. This is a “Lite” module restricting 8 ports to 1G speed but can be upgraded to 16 10G ports.

## QNI Modules

OmniSwitch 10K 40 Gigabit Network Interface (QNI) modules provide up to 8 40000 Mbps (40 Gbps) connections per module. The following 40 Gigabit modules are available:

- **OS10K-QNI-U4E.** Provides 4 QSFP+ transceiver connectors. Refer to [page 4-9](#) for information on this module.
- **OS10K-QNI-U8E.** Provides 8 QSFP+ transceiver connectors. Refer to [page 4-10](#) for information on this module.

---

**Note.** Transceivers are hot-pluggable—i.e., they can be installed or removed while the module is powered on and operating without the risk of damage to the transceiver or host circuitry. See “[Handling Fiber and Fiber Optic Connectors](#)” on [page 4-16](#) for proper handling of fiber and fiber-optic connectors.

---

# OS10K-GNI-C48E Front Panel

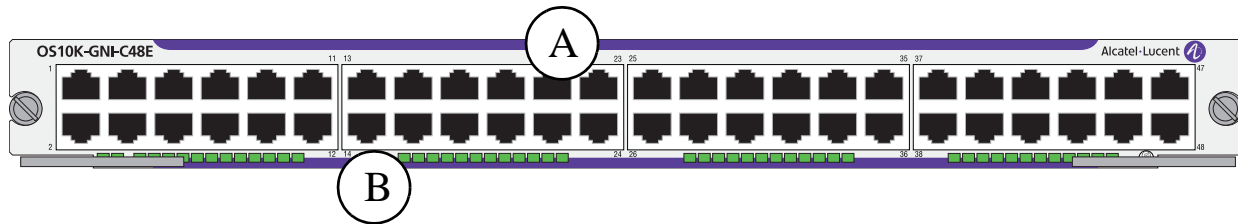

**OS10K-GNI-C48E Front Panel**

Item	Description
<b>A</b>	<b>Ethernet Ports</b> 48 auto-sensing, auto-negotiating and individually configurable as 10BaseT, 100BaseTX, or 1000BaseT.
<b>B</b>	<b>Port LEDs</b> Provides port link status. Refer to <a href="#">“Monitoring NI Modules”</a> on page 4-11 for LED status information.

## OS10K-GNI-C48E Technical Specifications

Number of Ports	48
Maximum frame size	9216 bytes
MAC addresses supported	32000 per module
Power	152 W

# OS10K-GNI-U48E Front Panel

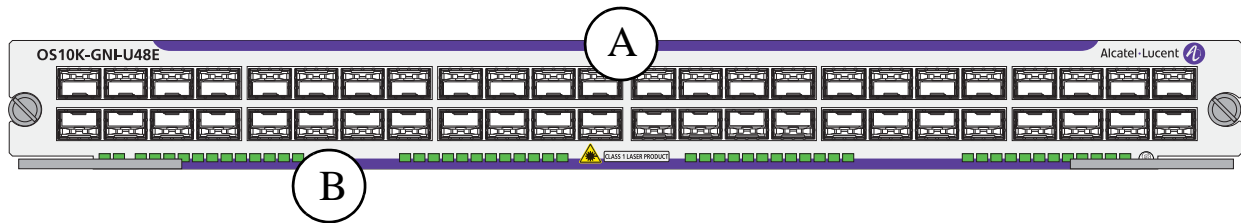

## OS10K-GNI-U48E Front Panel

Item	Description
<b>A</b>	<b>SFP Ports</b> 48 SFP connectors for supported transceivers.
<b>B</b>	<b>Port LEDs</b> Provides port link status. Refer to <a href="#">“Monitoring NI Modules”</a> on page 4-11 for LED status information.

### OS10K-GNI-U48E Technical Specifications

Number of SFP transceiver ports	48
Maximum frame size	9216 bytes
MAC addresses supported	32000 per module
SFP Transceivers	Refer to the <i>OmniSwitch 10K Transceivers Guide</i> for transceivers specifications.
Power	154 W



# OS10K-XNI-U32S Front Panel

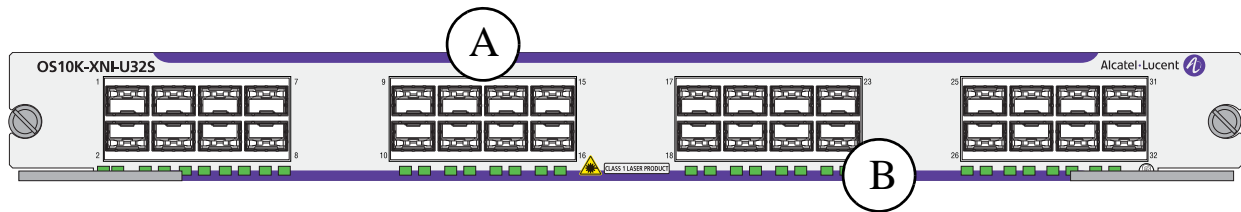

OS10K-XNI-U32S Front Panel

Item	Description
<b>A</b>	<b>SFP+ Ports</b> 32 SFP+ connectors for supported transceivers.
<b>B</b>	<b>Port LEDs</b> Provides port link status. Refer to <a href="#">“Monitoring NI Modules”</a> on page 4-11 for LED status information.

## OS10K-XNI-U32S Technical Specifications

Number of SFP+ ports	32
Maximum frame size	9216 bytes
MAC addresses supported	32000 per module
SFP+ Transceivers	Refer to the <i>OmniSwitch Transceivers Guide</i> for transceivers specifications.
Power	432 W

# OS10K-XNI-U32E Front Panel

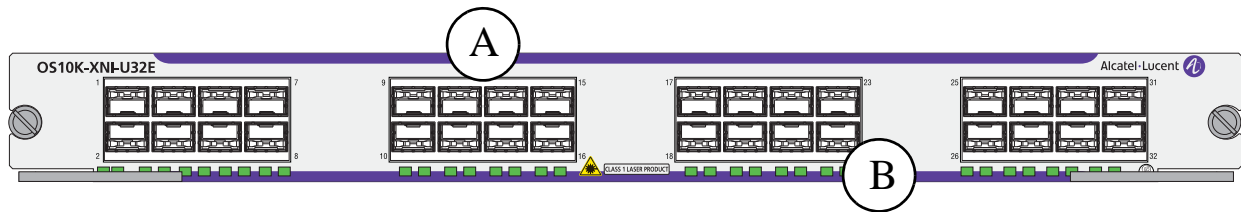

OS10K-XNI-U32E Front Panel

Item	Description
<b>A</b>	<b>SFP+ Ports</b> 32 SFP+ connectors for supported transceivers.
<b>B</b>	<b>Port LEDs</b> Provides port link status. Refer to <a href="#">“Monitoring NI Modules”</a> on page 4-11 for LED status information.

## OS10K-XNI-U32E Technical Specifications

Number of SFP+ ports	32
Maximum frame size	9216 bytes
MAC addresses supported	128K per module
SFP+ Transceivers	Refer to the <i>OmniSwitch Transceivers Guide</i> for transceivers specifications.
Power	424 W

# OS10K-XNI-U16E Front Panel

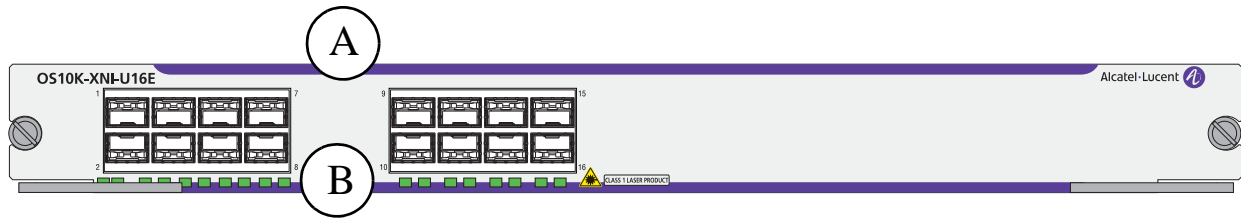

OS10K-XNI-U16E Front Panel

Item	Description
<b>A</b>	<b>SFP+ Ports</b> 16 SFP+ connectors for supported transceivers.
<b>B</b>	<b>Port LEDs</b> Provides port link status. Refer to <a href="#">“Monitoring NI Modules” on page 4-11</a> for LED status information.

## OS10K-XNI-U16E Technical Specifications

Number of SFP+ ports	16
Maximum frame size	9216 bytes
MAC addresses supported	128K per module
SFP+ Transceivers	Refer to the <i>OmniSwitch Transceivers Guide</i> for transceivers specifications.
Power	225 W

# OS10K-XNI-U16L Front Panel

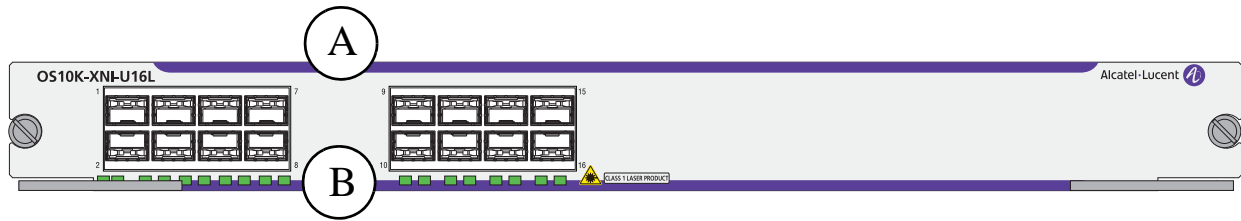

**OS10K-XNI-U16L Front Panel**

Item	Description
<b>A</b>	<b>SFP+ Ports</b> 16 SFP+ connectors for supported transceivers.
<b>B</b>	<b>Port LEDs</b> Provides port link status. Refer to <a href="#">“Monitoring NI Modules” on page 4-11</a> for LED status information.

## OS10K-XNI-U16L Technical Specifications

Number of SFP+ ports	16 <sup>1</sup>
Maximum frame size	9216 bytes
MAC addresses supported	128K per module
SFP+ Transceivers	Refer to the <i>OmniSwitch Transceivers Guide</i> for transceivers specifications.
Power	225 W

1. On this “Lite” module 8 ports (9-16) are restricted to 1G speed. This module can be upgraded to the same functionality as an OS10K-XNI-U16E (16 10G ports) with the U16L upgrade license.

# OS10K-QNI-U4E Front Panel

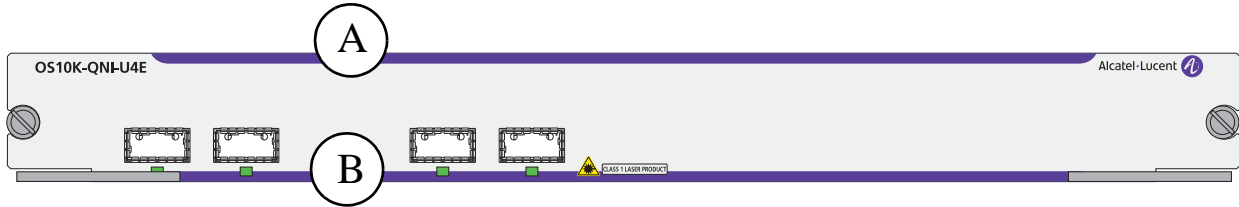

**OS10K-QNI-U4E Front Panel**

Item	Description
<b>A</b>	<b>QSFP+ Ports</b> 4 QSFP+ connectors for supported transceivers.
<b>B</b>	<b>Port LEDs</b> Provides port link status. Refer to <a href="#">“Monitoring NI Modules” on page 4-11</a> for LED status information.

## OS10K-QNI-U4E Technical Specifications

Number of QSFP+ ports	4
Maximum frame size	9216 bytes
MAC addresses supported	128K per module
SFP+ Transceivers	Refer to the <i>OmniSwitch Transceivers Guide</i> for transceivers specifications.
Power	218 W

# OS10K-QNI-U8E Front Panel

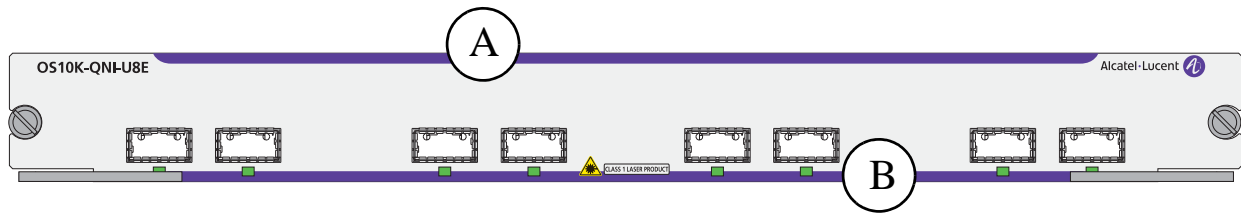

**OS10K-QNI-U8E Front Panel**

Item	Description
<b>A</b>	<b>SFP+ Ports</b> 8 QSFP+ connectors for supported transceivers.
<b>B</b>	<b>Port LEDs</b> Provides port link status. Refer to <a href="#">“Monitoring NI Modules” on page 4-11</a> for LED status information.

## OS10K-QNI-U8E Technical Specifications

Number of QSFP+ ports	8
Maximum frame size	9216 bytes
MAC addresses supported	128K per module
SFP+ Transceivers	Refer to the <i>OmniSwitch Transceivers Guide</i> for transceivers specifications.
Power	396 W

# Monitoring NI Modules

## Front Panel LEDs

All NIs provide a series of status LEDs located on the front panel. These LEDs offer basic status information for hardware operation, NI software status and port link and activity status.

LED	State	Description
ACT	Solid Green	Valid Link
	Blinking Green	Tx or Rx Activity

## Accessing General NI Information

The switch's Command Line Interface (CLI) offers NI monitoring commands. These commands allow you to access general NI hardware information as well as the current operating status.

To access general NI information, use the show module long command. For example:

```
-> show module long 3
Module in slot 3
  Model Name:                OS10-GNI-C48,
  Description:               10-1000 RJ45,
  Part Number:               543212345,
  Hardware Revision:         123,
  Serial Number:             123454321,
  Manufacture Date:          Jan 20 2010,
  FPGA - Physical 1:         007,
  Daughter FPGA - Physical 1: 002,
  Daughter FPGA - Physical 2: 002,
  Admin Status:              POWER ON,
  Operational Status:        UP,
  Max Power:                 250,
  Power Consumption:         200,
  CPU Model Type   :         Motorola MPC8540 ADS,
  MAC Address:               00:d0:95:01:03:01,
  ASIC - Physical 1:         BCM56620_A1,
  ASIC - Physical 2:         BCM56620_A1,
  ASIC - Physical 3:         BCM56620_A1,
  ASIC - Physical 4:         BCM56620_A1,
  ASIC - Physical 5:         BCM56620_A1,
  ASIC - Physical 6:         BCM56620_A1,
  UBOOT Version:             7.1.1.412.R01,
```

For more information about this display and other NI monitoring commands, see the “Chassis Management and Monitoring Commands” chapter in the *OmniSwitch CLI Reference Guide*.

# Removing and Adding NI Modules

## Eliminating Electrostatic Discharge (ESD)

Before handling modules, be sure to follow proper procedures to eliminate electrostatic discharge (ESD) from your person and the surrounding area before installing chassis components.

### Caution: Equipment Damage Hazard

When removing modules from the chassis, use one hand to support the rear of the module as shown. Failure to support the rear of the module may cause it to fall and strike the backplane connectors, resulting in permanent damage to the module.

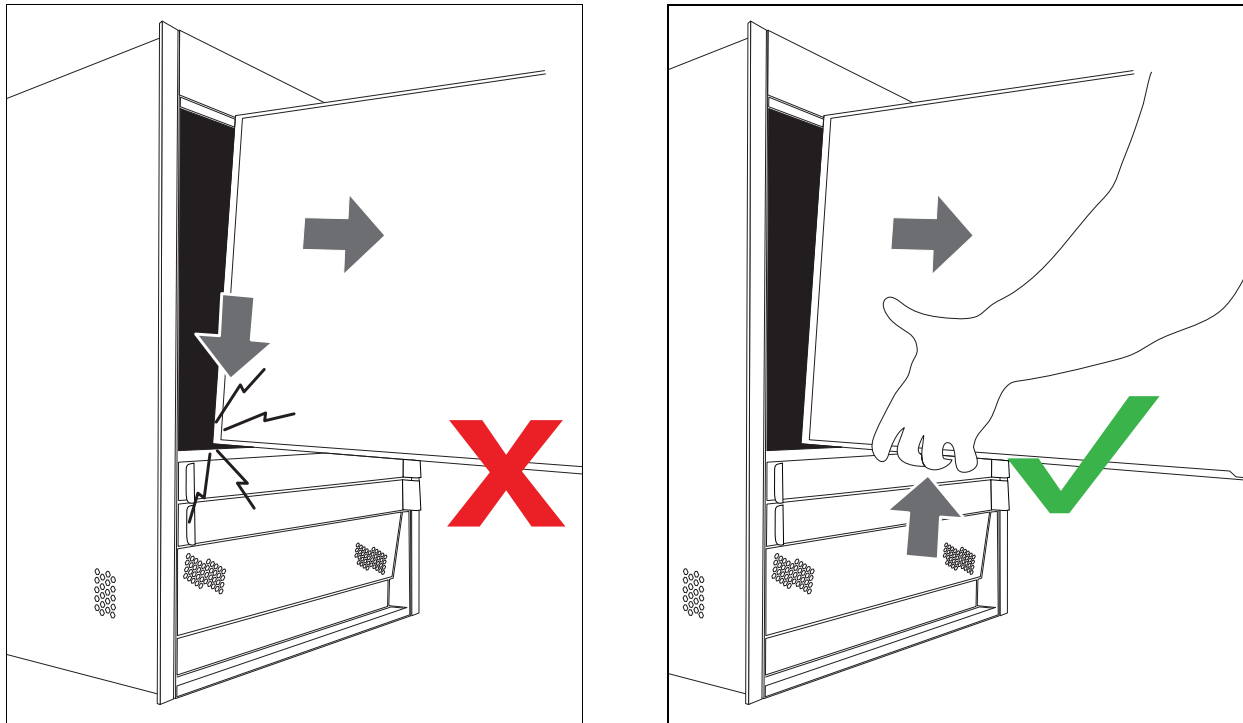

**Proper Module Support**



## Removing a Module

To remove an NI module, follow the steps below.

- 1 Loosen the module's two captive screws.
- 2 Simultaneously pull the two module lock levers—one on top of the module and one on the bottom—until the module disengages from the chassis.

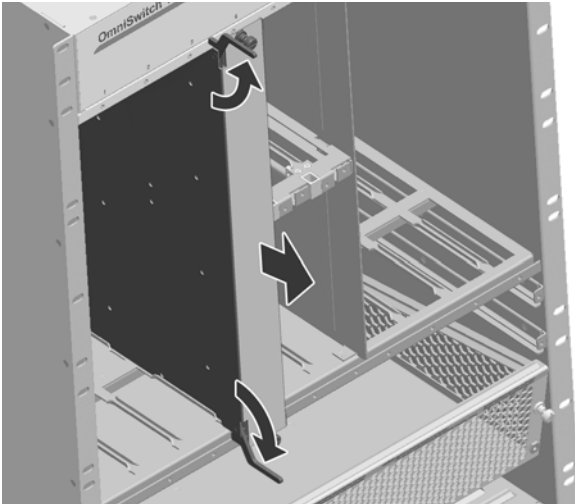

- 3 Slide the module out of the chassis.

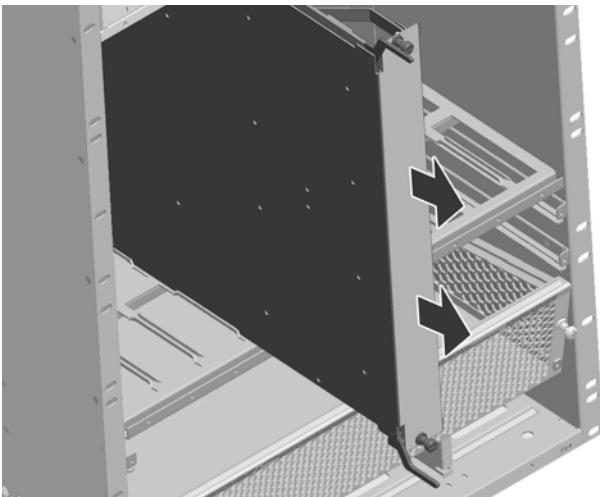

---

**Warning.** Use caution when removing modules as some components may be hot.

---

## Adding a Module

To add an NI module, follow the steps below:

- 1 Insert the module into the slot along the chassis card guides. The component side of the board should face right. The module should slide in easily.

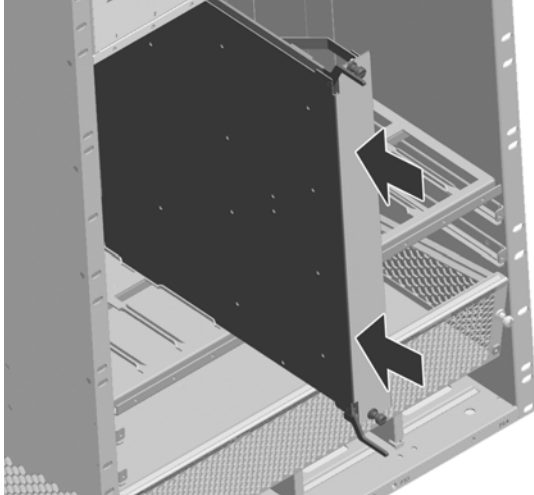

---

**Note.** Do not force the module into the slot. If any resistance is encountered, make sure the module is aligned properly in the card guides.

---

- 2 When the module is nearly seated in the slot, be sure that the two extractor levers—one on top of the module and one on the bottom—are open (approximately 90 degrees). This allows the notch on each extractor lever to grasp the rail on the chassis.
- 3 Once the notches have grasped the rail, press both extractor levers inward simultaneously until the module is firmly seated.

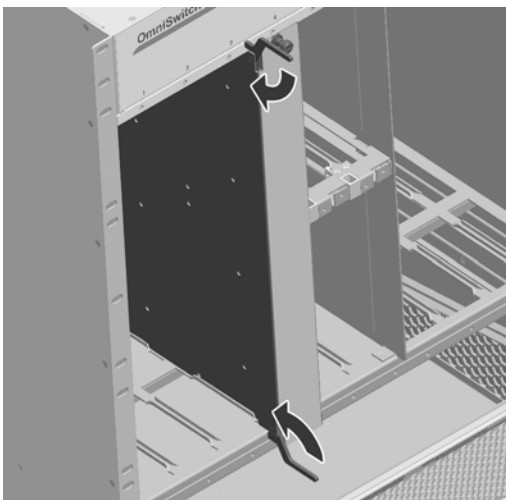

- 4 Once the module is firmly seated, secure the module to the chassis by tightening the two captive screws.

# Pinouts

## 10/100 Mbps Ethernet Port – RJ-45 Pinout

Pin Number	Description
1	RX+
2	RX-
3	TX+
4	not used
5	not used
6	TX-
7	not used
8	not used

## Gigabit Ethernet Port – RJ-45 Pinout

Pin Number	Description
1	BI_DB+
2	BI_DB-
3	BI_DA+
4	BI_DD+
5	BI_DD-
6	BI_DA-
7	BI_DC+
8	BI_DC-

# Handling Fiber and Fiber Optic Connectors

Using fiber is simple, but several important standards should always be practiced. For best results, you should:

- Use premium grade cables
- Keep your fiber optic connectors clean
- Keep the transceiver interface clean
- Attenuate properly

For detailed information on these recommendations, refer to the sections below:

## Use Premium Grade Cables

There are many brands of fiber optic jumper cables, with a wide range of quality between each manufacturer. Premium cables do three things well:

- They provide a good polish on the fiber optic connector endface (where the light exits the cable). Endface geometries must be exceptionally precise and aligned to extremely tight tolerances. The better the endface geometry, the lower the loss and more consistent the connection. Poor connector interfaces will reflect light back into the laser, causing an increase in laser noise.
- They mate well with other connector interfaces. Chances are the manufacturer of the jumper cable will not be the same as the manufacturer of the transceiver connector interface. Premium jumper cables mechanically align themselves well into most transceiver interfaces. This provides both better performance as well as better repeatability. You will always see a variance in transceiver power due to connector alignment, good jumper cables help reduce this variance.
- They continue to mate well after many insertions and removals. Premium grade jumper use premium connectors that maintain their mechanical integrity up to and beyond 2000 insertion cycles.

For better repeatability, always use duplex (two connectors fused together and terminated to two cables) connectors on your jumper cables when connecting to a fiber-optic transceiver.

Never bend the fiber optic cable beyond its recommended minimum bend radius. This introduces bend losses and reflections that will degrade the performance of your system. It can also damage the fiber, although fiber is much tougher than most would assume. Still, it is highly recommended to buy only jumper cables with 3mm Kevlar jacketing, which offer superior protection and longer life.

## Keep Your Fiber Optic Connectors Clean

Unlike electrical connectors, fiber-optic connectors must be extremely clean in order to ensure optimum system performance. Microscopic particles such as dust on the connector endface (i.e., where the light exits the connector) can degrade the performance of your system, often to the point of failure.

If you have low-power output from a fiber-optic transceiver or a fault signal from your equipment, begin the troubleshooting process by cleaning your fiber-optic connectors per manufacturer recommendations.

## Keep the Transceiver Interface Clean

If you have cleaned your connectors, but still experience low-power output from a fiber-optic transceiver or a fault signal from your equipment, you should clean the transceiver interface by blowing inert dusting gas inside the transceiver interface. This removes dust and other small particles that may block the optical path between the optics of the transceiver and the connector's endface.

## Attenuate Properly

Often, equipment using laser-based transceivers need to have the optical path attenuated when performing loop-back testing or testing between two pieces of equipment. Too much optical power launched into the receiver will cause saturation and result in system failure. If you are using single mode fiber and you do not know the power output of the laser, it is always best to use a 10 dB attenuator when testing. Using the wrong type of attenuator will introduce problems, most notably reflection of light back into the laser, often resulting in excess noise and causing system failure.

Inline attenuators eliminate the need for additional jumper cables and thus reduce the number of connection interfaces. This increases the integrity of the optical path resulting in a more accurate test.

---

**CAUTION** - Use of controls or adjustments or performance of procedures other than those specified herein may result in hazardous radiation exposure.

---



# A Regulatory Compliance and Safety Information

This appendix provides information on regulatory agency compliance and safety for OmniSwitch 10K switches.

## Declaration of Conformity: CE Mark

This equipment is in compliance with the essential requirements and other provisions of Directive 2004/108/EC (EMC), 2006/95/EC (LVD), 91/263/EEC (Telecom Terminal Equipment, if applicable), 1999/5/EC (R&TTE, if applicable).

**Français:** Cet équipement est conforme aux exigences essentielles et aux autres provisions de la Directive 2004/108/EC (EMC), 2006/95/CE (LVD), 91/263/CEE (équipements terminaux de télécommunications, le cas échéant), 1999/5/EC (R&TTE, le cas échéant).

**Deutsch:** Diese Ausrüstung erfüllt die wesentlichen Anforderungen und sonstigen Bestimmungen der Richtlinien 2004/108/EG (EMV-Richtlinie), 2006/95/EG (Niederspannungsrichtlinie), 91/263/EWG (Telekommunikationsendeinrichtungen, falls zutreffend), 1999/5/EG (Funkanlagen und Telekommunikationsendeinrichtungen, falls zutreffend).

**Español:** Este equipo cumple los requisitos esenciales y otras disposiciones de las directivas 2004/108/CE (EMC), 2006/95/CE (LVD), 91/263/CEE (equipos terminales de telecomunicación, si procede), 1999/5/CE (R&TTE, si procede).

## Waste Electrical and Electronic Equipment (WEEE) Statement

The product at end of life is subject to separate collection and treatment in the EU Member States, Norway and Switzerland and therefore marked with the following symbol:

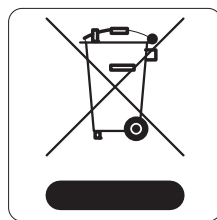

Treatment applied at end of life of the product in these countries shall comply with the applicable national laws implementing directive 2002/96/EC on waste electrical and electronic equipment (WEEE).

# China RoHS: Hazardous Substance Table

## 产品说明书附件

### SUPPLEMENT TO PRODUCT INSTRUCTIONS

**这个文件涉及的是在中华人民共和国境内进口或销售的电子信息产品  
Include this document with all Electronic Information Products imported  
or sold in the People's Republic of China**

部件名称 (Parts)	有毒有害物质或元素 (Hazardous Substance)					
	铅 (Pb)	汞 (Hg)	镉 (Cd)	六价铬 (Cr <sup>6+</sup> )	多溴联苯 (PBB)	多溴二苯醚 (PBDE)
电路模块 (Circuit Modules)	×	○	○	○	○	○
电缆及电缆组件 (Cables & Cable Assemblies)	×	○	○	○	○	○
金属部件 (Metal Parts)	×	○	○	○	○	○
塑料和聚合物部件 (Plastic and Polymeric parts)	○	○	○	○	○	○
对于交付时集成了电池的电子信息产品 For electronic information products delivered with integrated functional batteries:						
电池 (Batteries)	○	○	○	○	○	○
<p>○ : 表示该有毒有害物质在该部件所有均质材料中的含量均在 SJ/ T11363-2006 标准规定的限量要求以下。 Indicates that the concentration of the hazardous substance in all homogeneous materials in the parts is below the relevant threshold of the SJ/T11363-2006 standard.</p> <p>× : 表示该有毒有害物质至少在该部件的某一均质材料中的含量超出SJ/ T11363-2006标准规定的限量要求。 Indicates that the concentration of the hazardous substance of at least one of all homogeneous materials in the parts is above the relevant threshold of the SJ/T11363-2006 standard.</p> <p>对销售之日的所售产品, 本表显示, 阿尔卡特朗讯公司供应链的电子信息产品可能包含这些物质。注意: 在所售产品中可能会也可能不会含有所有所列的部件。 <b>This table shows where these substances may be found in the supply chain of Alcatel-Lucent electronic information products, as of the date of sale of the enclosed product. Note that some of the component types listed above may or may not be a part of the enclosed product.</b></p>						

除非另外特别的标注, 此标志为针对所涉及产品的环保使用期标志。某些零部件会有一个不同的环保使用期(例如, 电池单元模块)贴在其产品上。  
此环保使用期限只适用于产品是在产品手册中所规定的条件下工作。  
The Environment-Friendly Use Period (EFUP) for all enclosed products and their parts are per the symbol shown here, unless otherwise marked. Certain parts may have a different EFUP (for example, battery modules) and so are marked to reflect such. The Environment-Friendly Use Period is valid only when the product is operated under the conditions defined in the product manual.





Products are packaged using one or more of the following packaging materials:

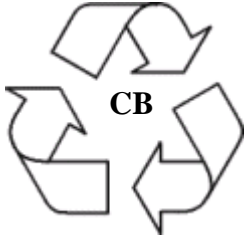

**Corrugated Cardboard**

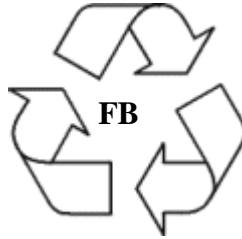

**Corrugated Fiberboard**



**LDPE**

**Low-Density Polyethylene**

# Standards Compliance

The product bears the CE mark. In addition it is in compliance with the following other safety and EMC standards:

All hardware switching modules used in an OmniSwitch 10K switch comply with Class A standards. Modules with copper connectors meet Class A requirements using unshielded (UTP) cables.

## Safety Standards

- UL 60950-1, 2nd Edition
- CAN/CSA-C22.2 No. 60950-1-07, 2nd Edition
- EN 60950-1 with Amendment II
- IEC 60950-1 2nd Edition
- AS/NZS TS-001 and 60950:, Australia
- UL-AR, Argentina
- TUV,UL-GS Mark, Germany
- NOM-019 SCFI, Mexico
- EN 60825-1 Laser
- EN 60825-2 Laser
- CDRH Laser
- CB Certification per IEC 60950-1, Second Edition

## EMC Standards

- FCC Part 15 (CFR 47) Class A
- ICES-003 Class A
- EN 55022: Class A
- CISPR 22 Class A
- AS/NZS 3548 Class A
- VCCI Class A; A1 and A2
- EN 55024 (Immunity)
- EN 61000-3-2
- EN 61000-3-3
- EN 61000-4-2
- EN 61000-4-3
- EN 61000-4-4
- EN 61000-4-5
- EN 61000-4-6
- EN 61000-4-8
- EN 61000-4-11

## Environmental Standards

- ETS 300 019 Storage Class 1.1
- ETS 300 019 Transportation Class 2.3
- ETS 300 019 Stationary Use Class 3.1

## FCC Class A, Part 15

This equipment has been tested and found to comply with the limits for Class A digital device pursuant to Part 15 of the FCC Rules. These limits are designed to provide reasonable protection against harmful interference when the equipment is operated in a commercial environment. This equipment generates, uses, and can radiate radio frequency energy and, if not installed and used in accordance with the instructions in this guide, may cause interference to radio communications. Operation of this equipment in a residential area is likely to cause interference, in which case the user will be required to correct the interference at his own expense.

The user is cautioned that changes and modifications made to the equipment without approval of the manufacturer could void the user's authority to operate this equipment. It is suggested that the user use only shielded and grounded cables to ensure compliance with FCC Rules.

If this equipment does cause interference to radio or television reception, the user is encouraged to try to correct the interference by one or more of the following measures:

- Reorient the receiving antenna.
- Relocate the equipment with respect to the receiver.
- Move the equipment away from the receiver.
- Plug the equipment into a different outlet so that equipment and receiver are on different branch circuits.

If necessary, the user should consult the dealer or an experienced radio/television technician for additional suggestions.

## Canada Class A Statement

This equipment does not exceed Class A limits per radio noise emissions for digital apparatus, set out in the Radio Interference Regulation of the Canadian Department of Communications.

### **Avis de conformité aux normes du ministère des Communications du Canada**

Cet équipement ne dépasse pas les limites de Classe A d'émission de bruits radioélectriques pour les appareils numériques, telles que prescrites par le Règlement sur le brouillage radioélectrique établi par le ministère des Communications du Canada.

## JATE

This equipment meets the requirements of the Japan Approvals Institute of Telecommunications Equipment (JATE).

## CISPR22 Class A warning

This is a Class A product. In a domestic environment, this product may cause radio interference. Under such circumstances, the user may be requested to take appropriate countermeasures.

## VCCI

This is a Class A product based on the standard of the Voluntary Control Council for Interference by Information Technology Equipment (VCCI). If this equipment is used in a domestic environment, radio disturbance may arise. When such trouble occurs, the user may be required to take corrective actions.

この装置は、情報処理装置等電波障害自主規制協議会（VCCI）の基準に基づくクラスA情報技術装置です。この装置を家庭環境で使用すると電波妨害を引き起こすことがあります。この場合には使用者が適切な対策を講ずるよう要求されることがあります。

## Class A Warning for Taiwan and Other Chinese Markets

This is a Class A Information Product. When used in a residential environment, it may cause radio frequency interference. Under such circumstances, the user may be requested to take appropriate countermeasure.

**警告使用者：**  
這是甲類的資訊產品，在居住的環境中使用時，可能會造成射頻干擾，在這種情況下，使用者會被要求採取某些適當的對策。

# Translated Safety Warnings

## Chassis Lifting Warning

Two people are required when lifting the chassis. Due to its weight, lifting the chassis unassisted can cause personal injury. Also be sure to bend your knees and keep your back straight when assisting with the lifting of the chassis.

**Français:** Le châssis doit être soulevé par deux personnes au minimum. Pour éviter tout risque d'accident, maintenez le dos droit et poussez sur vos jambes. Ne soulevez pas l'unité avec votre dos.

**Deutsch:** Hinweise zur Anhebung des Chassis Zum Anheben des Chassis werden zwei Personen benötigt. Aufgrund des Gewichts kann das Anheben ohne Unterstützung zu Personenschäden führen. Heben Sie das Chassis aus den Knien und halten Sie den Rücken gerade wenn Sie beim Anheben des Chassis assistieren.

**Español:** Se requieren dos personas para elevar el chasis. Para evitar lesiones, mantenga su espalda en posición recta y levante con sus piernas, no con su espalda.

## Blank Panels Warning

Because they regulate airflow and help protect internal chassis components, blank cover plates should remain installed at empty module slots and power supply bays at all times.

**Français:** Les caches blancs remplissent trois fonctions importantes: ils évitent tout risque de choc électrique à l'intérieur du châssis, ils font barrage aux interférences électromagnétiques susceptibles d'altérer le fonctionnement des autres équipements et ils dirigent le flux d'air de refroidissement dans le châssis. Il est vivement recommandé de vérifier que tous les caches, modules d'alimentation et plaques de protection sont en place avant d'utiliser le système.

**Deutsch:** Die leeren Modulblenden schützen interne Komponenten und leiten den Luftstrom. Deshalb müssen in allen unbelegten Slots die Modulblenden immer installiert bleiben.

**Español:** Las tapaderas blancas regulan la circulación de aire y ayudan a proteger componentes internos del chasis y siempre deben estar instaladas en las ranuras vacías del chasis y fuentes de alimentación.

## Electrical Storm Warning

To avoid a shock hazard, do not connect or disconnect any cables or perform installation, maintenance, or reconfiguration of this product during an electrical storm.

**Français:** Ne pas travailler sur le système ni brancher ou débrancher les câbles pendant un orage.

**Deutsch:** Um elektrische Schläge zu vermeiden dürfen während eines Gewitters and diesem Gerät keine Kabel angeschlossen oder gelöst werden, sowie keinerlei Installationen, Wartungen oder Konfigurationen vorgenommen werden.

**Español:** Para evitar peligro de descargas, no conecte o desconecte ningún cable, ni realice ninguna instalación, mantenimiento o reconfiguración de este producto durante una tormenta eléctrica.

## Installation Warning

Only personnel knowledgeable in basic electrical and mechanical procedures should install or maintain this equipment.

**Français:** Toute installation ou remplacement de l'appareil doit être réalisée par du personnel qualifié et compétent.

**Deutsch:** Dieses Gerät soll nur von Personal installiert oder gewartet werden, welches in elektrischen und mechanischen Grundlagen ausgebildet ist.

**Español:** Estos equipos deben ser instalados y atendidos exclusivamente por personal adecuadamente formado y capacitado en técnicas eléctricas y mecánicas.

## Invisible Laser Radiation Warning

Lasers emit invisible radiation from the aperture opening when no fiber-optic cable is connected. When removing cables do not stare into the open apertures. In addition, install protective aperture covers to fiber ports with no cable connected.

**Français:** Des radiations invisibles à l'œil nu pouvant traverser l'ouverture du port lorsque aucun câble en fibre optique n'y est connecté, il est recommandé de ne pas regarder fixement l'intérieur de ces ouvertures. Installez les caches connecteurs prévus à cet effet.

**Deutsch:** Die Laser strahlen an der Blendenöffnung unsichtbares Licht ab, wenn keine Glasfaserkabel angeschlossen sind. Blicken Sie nicht in die Öffnungen und installieren Sie unverzüglich die Abdeckungen über den Glasfaseranschlüssen.

**Español:** Debido a que la apertura del puerto puede emitir radiación invisible cuando no hay un cable de fibra conectado, procurar no mirar directamente a las aperturas para no exponerse a la radiación.

## Operating Voltage Warning

To reduce the risk of electrical shock, keep your hands and fingers out of power supply bays and do not touch the backplane while the switch is operating.

**Français:** Pour réduire tout risque électrique, gardez vos mains et doigts hors des alimentations et ne touchez pas au fond de panier pendant que le commutateur fonctionne.

**Deutsch:** Um die Gefahr des elektrischen Schlages zu verringern, greifen sie bitte nicht in die Spannungsversorgung und berühren sie nicht die Rückwandplatine während das Gerät arbeitet.

**Español:** Para reducir el riesgo de descargas eléctricas, no meta sus manos y dedos dentro del chasis de la fuente de alimentación y no toque componentes internos mientras que el interruptor está conectado.

## Power Disconnection Warning

Your switch is equipped with multiple power supplies. To reduce the risk of electrical shock, be sure to disconnect all power connections before servicing or moving the unit.

**Français:** Il se peut que cette unité soit équipée de plusieurs raccordements d'alimentation. Pour supprimer tout courant électrique de l'unité, tous les cordons d'alimentation doivent être débranchés.

**Deutsch:** Ihr Gerät ist mit mehreren Netzteilen ausgerüstet. Um die Gefahr des elektrischen Schlages zu verringern, stellen sie sicher, daß alle Netzverbindungen getrennt sind bevor das Gerät gewartet oder bewegt wird.

**Español:** Antes de empezar a trabajar con un sistema, asegúrese que el interruptor está cerrado y el cable eléctrico desconectado.

## Proper Earthing Requirement Warning

To avoid shock hazard:

- The power cord must be connected to a properly wired and earth receptacle.
- Any equipment to which this product will attached must also be connected to properly wired receptacles.

### Français:

Pour éviter tout risque de choc électrique:

- Ne jamais rendre inopérant le conducteur de masse ni utiliser l'équipement sans un conducteur de masse adéquatement installé.
- En cas de doute sur la mise à la masse appropriée disponible, s'adresser à l'organisme responsable de la sécurité électrique ou à un électricien.

### Deutsch:

Aus Sicherheitsgründen:

- darf das Netzkabel nur an eine Schutzkontaktsteckdose angeschlossen werden.
- dürfen für den Anschluß anderer Geräte, welche mit diesem Gerät verbunden sind, auch nur Schutzkontaktsteckdosen verwendet werden.

### Español:

Para evitar peligro de descargas:

- Para evitar peligro de descargas asegúrese de que el cable de alimentación está conectado a una toma de alimentación adecuadamente cableada y con toma de tierra.
- Cualquier otro equipo a cual se conecte este producto también debe estar conectado a tomas de alimentación adecuadamente cableadas.

## DC Power Supply Connection Warning

For EMC/EMI, each DC/DC power supply requires that the ground wire is connected from each DC/DC power supply to Common Earth Ground.

**Français:** Pour EMC/EMI, pour chaque alimentation DC/DC, il est impératif que le fil de terre soit branché à la prise de terre commune.

**Deutsch:** Zur Erfüllung der EMV-/EMI-Anforderungen muss das Erdungskabel jedes DC/DC-Netzteils an eine gemeinsame Erde angeschlossen werden.

**Español:** Para EMC/EMI, cada fuente de alimentación de CC/CC requiere que el cable de tierra esté conectado desde cada fuente de alimentación de CC/CC a la conexión a tierra común.

## Read Important Safety Information Warning

The *Getting Started Guide* that accompanied this equipment contains important safety information about which you should be aware when working with hardware components in this system. You should read this guide before installing, using, or servicing this equipment.

**Français:** Avant de brancher le système sur la source d'alimentation, consultez les directives d'installation disponibles dans le "Getting Started Guide".

**Deutsch:** Der Getting Started Guide, welcher diese Anlage beiliegt, enthält wichtige Sicherheitsinformationen, über die sie sich beim Arbeiten mit den Hardwareeinheiten bewußt sein sollten. Sie sollten diese Hinweise lesen, bevor sie installieren, reparieren oder die Anlage verwenden.

**Español:** La 'Getting Started Guide' que acompañó este equipo contiene información importante de seguridad sobre la cual usted debe estar enterado al trabajar con los componentes de dotación física en este sistema. Usted debe leer esta guía antes de instalar, usar o mantener este equipo.

## Restricted Access Location Warning

This equipment should be installed in a location that restricts access. A restricted access location is one where access is secure and limited to service personnel who have a special key, or other means of security.

**Français:** Le matériel doit être installé dans un local avec accès limité ou seules les personnes habilitées peuvent entrer.

**Deutsch:** Die Anlage sollte an einem Standort mit beschränktem Zutritt installiert sein. Ein Standort mit beschränktem Zutritt stellt sicher, daß dort nur Servicepersonal mit Hilfe eines Schlüssels oder eines anderen Sicherheitssystems Zugang hat.

**Español:** Este equipo se debe instalar en un sitio con acceso restringido. Un sitio con el acceso restringido es uno seguro y con acceso limitado al personal de servicio que tiene una clave especial u otros medios de seguridad.



## Wrist Strap Warning

Because electrostatic discharge (ESD) can damage switch components, you must follow proper procedures to eliminate ESD from your person and the surrounding area before handling switch components. A grounding wrist strap is provided with your Alcatel-Lucent OmniSwitch 10K product.

**Français:** L'électricité statique (ESD) peut endommager les composants du commutateur. Pour cette raison Alcatel-Lucent joint à l'envoi du châssis un bracelet antistatique à brancher sur la prise mise à la terre située en bas à droite du commutateur. Vous devrez mettre ce bracelet avant toute intervention hardware.

**Deutsch:** Weil elektrostatische Aufladung (ESD) Teile der Anlage beschädigen könnten, müssen sie sich selbst erden, bevor sie mit der Hardware Installation beginnen. Zu diesem Zweck stellt Alcatel-Lucent ein Erdungsarmband und eine Erdungsöse an der oberen rechten Seite des Chassis zur Verfügung. Um eine sichere Erdungsfunktion des Erdungsarmbandes sicherzustellen, müssen die Netzteile installiert und mit dem Schutzleiter des Versorgungsstromkreises verbunden sein.

**Español:** La descarga electrostática (ESD) puede dañar componentes electrónicos. Usted debe asegurarse que está en contacto con tierra antes de hacer la instalación del equipo. Con este fin, Alcatel-Lucent proporciona una pulsera de muñeca para conectar al chasis en la toma de tierra situada en la parte superior derecha del chasis. Para que la correa de muñeca sea eficaz en la eliminación de ESD, las fuentes de alimentación deben estar instaladas en el chasis y conectadas a enchufes CA con tierra adecuada.

# Instrucciones de seguridad en español

## Advertencia sobre el levantamiento del chasis

Se requieren dos personas para levantar el chasis. Debido a su peso, la elevación del chasis sin ayuda puede causar daños corporales. También es seguro doblar sus rodillas y guardar su espalda derecho al ayudar a levantar el chasis.

## Advertencia de las tapaderas en blanco

Porque regulan la circulación de aire y ayudan a proteger componentes internos del chasis, las tapaderas en blanco deben seguir instaladas en las ranuras vacías del módulo y la fuente de alimentación siempre.

## Advertencia en caso de tormenta eléctrica

Para evitar peligro de descargas, no conecte o desconecte ningún cable, ni realice ninguna instalación, mantenimiento o reconfiguración de este producto durante una tormenta eléctrica.

## Advertencia de instalación

Solamente el personal bien informado en procedimientos eléctricos y mecánicos básicos debe instalar o mantener este equipo.

## Advertencia de radiación láser invisible

Los lasers emiten radiación invisible de la apertura abierta cuando no se conecta ningún cable de fibra óptica. Al quitar los cables no mire fijamente en las aberturas abiertas. Además, instale las cubiertas protectoras de la apertura a las salidas de la fibra sin el cable conectado.

## Advertencia de la batería de litio

Hay un peligro de la explosión si la batería del litio en su chasis se substituye incorrectamente. Substituya la batería solamente por el mismo o el equivalente de tipo de batería recomendado por el fabricante. Deseche las baterías usadas según las instrucciones del fabricante. Las instrucciones del fabricante son como sigue: Devuelva el módulo con la batería del litio a Alcatel-Lucent. La batería del litio será substituida en la fábrica de Alcatel-Lucent.

## Advertencia sobre la tensión de operación

Para reducir el riesgo del choque eléctrico, mantenga sus manos y dedos fuera de la fuente de alimentación y no toque la placa madre mientras que el interruptor está funcionando.

## Advertencia sobre la desconexión de la fuente

Su interruptor esta equipado por fuentes de alimentación múltiples. Para reducir el riesgo de choque eléctrico, asegúrese desconectar todas las conexiones de alimentación antes de mantener o de mover la unidad.

## **Advertencia sobre una apropiada conexión a tierra**

Para evitar peligro de descargas:

- El cable de alimentación debe estar conectado a una toma de alimentación adecuadamente cableada y con toma de tierra.

Cualquier equipo al cual se conecte este producto debe estar también conectado a tomas de alimentación adecuadamente cableadas.

## **Leer “información importante de seguridad”**

La *Guía de “Comenzando a Usar”* que acompaña este equipo contiene información importante de seguridad sobre la cual usted debe saber al trabajar con los componentes de dotación física en este sistema. Usted debe leer esta guía antes de instalar, de usar, o de mantener este equipo.

## **Advertencia de acceso restringido**

Este equipo se debe instalar en una ubicación que restrinja el acceso. Una ubicación con acceso restringido es una donde está seguro y limitado el acceso al personal de servicio que tiene un clave especial, u otros medios de la seguridad.

## **Advertencia de pulsera antiestática**

Debido a que la descarga electrostática (ESD) puede dañar componentes del interruptor, usted debe conectarse a tierra correctamente antes de continuar con la instalación del equipo. Para este propósito, Alcatel-Lucent proporciona una pulsera antiestática y un terminal que pone a tierra situados cerca de la parte superior derecha del chasis. Para que la pulsera antiestática sea eficaz en la eliminación de ESD, las fuentes de alimentación se deben instalar en el chasis y enchufar en las salidas de CA con descarga a tierra.

## **Clase de seguridad**

Cumple con 21CFR 1040.10 y 1040.11 ó sus equivalentes.

## **Advertencia de fuentes de poder**

Las unidades OmniSwitch 10K pueden estar equipadas con tres cordones para fuente de poder. Para reducir el riesgo de un choque eléctrico, desconecte todos los cordones de fuente de poder antes de dar servicio a la unidad.

